

调速电动机 SPEED ADJUSTABLE MOTOR

■ 6W □ 60mm



规格 Specs 连续额定 Cont. Rated

型号Model · 类型 Type 导线型 Lead Wire Type		最大 输出功率 Output power W	电压 Voltage V	频率 Frequency Hz	调速范围 Speed Control Range r/min	容许转矩 Allowance Torque		启动转矩 Starting Torque mN.m	电流 Current A	电容器容量 Capacitor μF
齿轮轴型 Pinion Shaft	圆轴型 Round Shaft					1200r/min mN.m	90r/min mN.m			
2IK6RGN-A	2IK6RA-A	6	1ph 100	50	90~1350	50	30	35	0.240	3.5
					90~1650	50	29	35	0.250	
2IK6RGN-E	2IK6RA-E	6	1ph 110	60	90~1650	50	29	30	0.160	2.0
			1ph 120						0.180	
2IK6RGN-C	2IK6RA-C	6	1ph 220	50	90~1350	55	29	35	0.130	0.8
			1ph 230						0.110	
2IK6RGN-H	2IK6RA-H	6	1ph 220	60	90~1650	55	29	35	0.140	0.8
			1ph 230						0.120	

●各种安全规格以电动机铭牌上的型号取得认证。

When the motor is approved under various safety standards, the model name on the nameplate is the approved model name.

●注：“-A”型号中电压为110V时，配置电容器容量以实际铭牌为准。

Note: "-A" it means the voltage 110V, the assembly capacitor vaule it is according the labe.

种类 Type

● 电动机 Motor

机型 Type	型号Model	
	齿轮轴型 Pinion Shaft	圆轴型 Round Shaft
导线型 Lead Wire Type	2IK6RGN-A	2IK6RA-A
	2IK6RGN-E	2IK6RA-E
	2IK6RGN-C	2IK6RA-C
	2IK6RGN-H	2IK6RA-H

● 平行轴减速器 (另售) Parallel Shaft Gearhead (Sold Separately)

减速器种类 Gearhead Type	减速器型号 Gearhead Model	减速比 Gear Ratio
长寿命●低噪音 Long Life ● Low Noise	2GN□K	3、3.6、5、6、7.5、9、10、 12.5、15、18、20、25、30、 36、40、50、60、75、90、 100、120、150、180、200
	2GN10XK (中间减速器 Decimal Gearhead)	

●减速器型号的□中为减速比的数值

Enter the gear ratio in the box (□) within the model name

■ 装有减速器时的容许转矩 Gear Motor-Torque Table

- 减速器另售·中间减速器另售。
Gearhead and mid-gearbox can be sold separately.
- 减速品型号的□中为减速比的数值。
Enter the gear ratio in the box (□) within the model name.
- □色表示与电动机同一方向运转，其他则为相反方向。
The colored background □ indicates the same rotating direction of the motor while the rotating direction of others are opposite.
- 转速是以电动机的同步转速（50Hz：1500r/min、60Hz：1800r/min）为基准除以减速比而算出来的数值。实际转速将随负载大小变化所示数值减少2%~20%左右。
The speed is calculated by dividing the motor's synchronous speed (50Hz：1500r/min、60Hz：1800r/min) by the gear ratio. The actual speed is 2%~20% less than the displayed value, depending on the size of the load.
- 希望以大于下表的减速比进行进一步减速时，可在电动机与减速机之间安装减速比为10的中间减速器。这时的容许转矩为3N·m。
To reduce the speed beyond the gear ratio in the table, attach a decimal gearhead (gear ratio:10) between the gearhead and motor. In that case, the permissible torque is 3N·m.

■ 容许力矩单位 Allowance Torque Unit：上段 Upside (N.m) /下段 Belowside (kgf.cm)

类型 Type 电动机/减速机 Motor/Gearhead	减速比 Gear Ratio		3	3.6	5	6	7.5	9	10	12.5	15	18	20	25	30	36	40	50	60	75	90	100	120	150	180	200
	转速 Speed r/min	50Hz	500	417	300	250	200	166	150	120	100	83	75	60	50	41	37	30	25	20	16	15	12.5	10	8.3	7.5
2IK6RGN-A 2IK6RGN-E 2IK6RGN-C 2IK6RGN-H	2GN□K	50Hz	0.12	0.14	0.19	0.23	0.29	0.35	0.39	0.49	0.58	0.70	0.75	0.88	1.10	1.30	1.39	1.60	1.90	2.40	2.90	3.00	3.00	3.00	3.00	3.00
		60Hz	1.22	1.43	1.94	2.35	2.96	3.57	3.98	5.00	5.92	7.14	7.65	8.98	11.2	13.3	14.2	16.3	19.4	24.5	29.6	30.0	30.0	30.0	30.0	30.0
	60Hz	0.10	0.12	0.16	0.19	0.24	0.29	0.32	0.41	0.49	0.58	0.62	0.73	0.88	1.10	1.15	1.30	1.60	2.00	2.40	2.60	3.00	3.00	3.00	3.00	3.00
		1.02	1.22	1.63	1.94	2.45	2.96	3.26	4.18	5.00	5.92	6.32	7.45	8.98	11.2	11.7	13.3	16.3	20.4	24.5	2.65	30.0	30.0	30.0	30.0	30.0

■ 容许悬挂负载·容许轴向负载 To Allow The Hoisting Of The Load Allow Axial Load

电动机（圆轴型）→P215页

Motor (Round shaft) →P215

减速机→P215页

Gearhead→P215

■ 减速机的容许负载惯性惯量 J Permissible Load Inertia J For Gearhead

→P215页→P215

■ 外形图（单位 mm）Dimensions (Unit mm)

减速机附有安装用螺丝 Mounting screws are included with gearhead.

● 导线型 Lead Wiring Type

重量 Weight：电动机 Motor：1.1kg

减速机 Gearhead：0.5kg

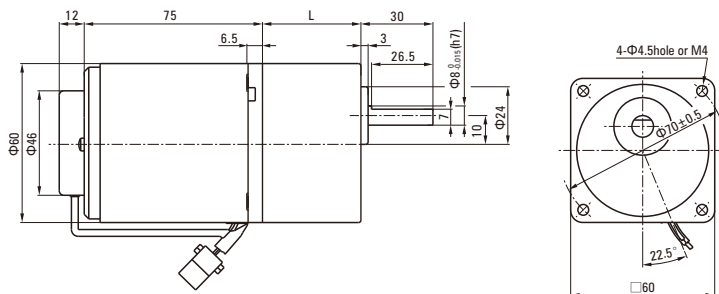

电动机型号 Motor Model	减速器型号 Gearhead Model	减速比 Gear Ratio	L1
2IK6RGN-A 2IK6RGN-E 2IK6RGN-C 2IK6RGN-H	2GN□K	3~200	41.5

- 减速器型号的□中为减速比的数值
Enter the gear ratio in the box (□) within the model name
- 减速比3~18可以做成短箱体 (L1=32)
Gear ratio 3~18, short case is possible (L1=32)

● 圆轴型的转轴部分 Shaft Section Of Round Shaft Type

除重量及轴部外电动机外形与齿轮轴型相同。
Excluding weight and the shaft section motor shape are the same as those of the pinion shaft type.

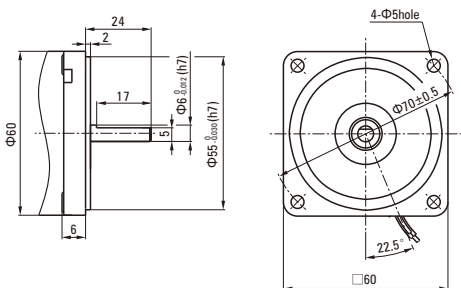

● 中间减速器 Decimal Gearhead

可安装在GN齿轮轴型上 Can be connected to GN pinion shaft type
电动机外形与齿轮轴型相同
2GN10XK
重量 Weight : 0.24kg

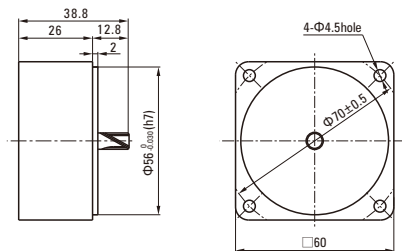

■ 连接图 Wiring Diagram

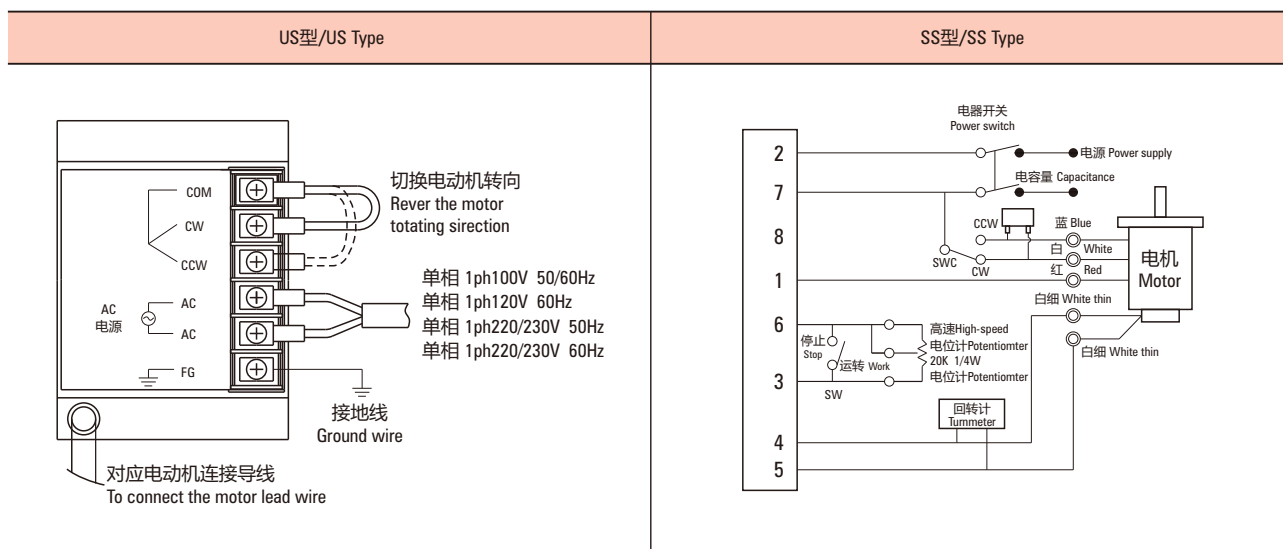

调速电动机 SPEED ADJUSTABLE MOTOR

■ 15W □ 70mm

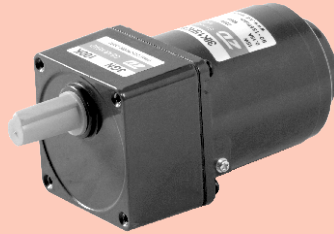

规格 Specs 连续额定 Cont. Rated

型号 Model · 类型 Type 导线型 Lead Wire Type		最大 输出功率 Output power W	电压 Voltage V	频率 Frequency Hz	调速范围 Speed Control Range r/min	容许转矩 Allowance Torque		启动转矩 Starting Torque mN.m	电流 Current A	电容器容量 Capacitor μF
齿轮轴型 Pinion Shaft	圆轴型 Round Shaft					1200r/min mN.m	90r/min mN.m			
3IK15RGN-A	3IK15RA-A	15	1ph 100	50	90~1350	120	35	55	0.35	6.0
				60	90~1650				0.33	
3IK15RGN-E	3IK15RA-E	15	1ph 110	60	90~1650	125	35	55	0.30	5.0
			1ph 120						0.32	
3IK15RGN-C	3IK15RA-C	15	1ph 220	50	90~1350	120	35	54	0.18	1.2
			1ph 230						0.20	
3IK15RGN-H	3IK15RA-H	15	1ph 220	60	90~1650	85	35	52	0.16	1.2
			1ph 230			105			55	

●各种安全规格以电动机铭牌上的型号取得认证。

When the motor is approved under various safety standards, the model name on the nameplate is the approved model name.

●注：“-A”型号中电压为110V时，配置电容器容量以实际铭牌为准。

Note: "-A" it means the voltage 110V, the assembly capacitor vaule it is according the labe.

种类 Type

● 电动机 Motor

机型 Type	型号 Model	
	齿轮轴型 Pinion Shaft	圆轴型 Round Shaft
导线型 Lead Wire Type	3IK15RGN-A	3IK15RA-A
	3IK15RGN-E	3IK15RA-E
	3IK15RGN-C	3IK15RA-C
	3IK15RGN-H	3IK15RA-H

● 平行轴减速器（另售） Parallel Shaft Gearhead (Sold Separately)

减速器种类 Gearhead Type	减速器型号 Gearhead Model	减速比 Gear Ratio
长寿命●低噪音 Long Life ● Low Noise	3GN□K	3、3.6、5、6、7.5、9、10、 12.5、15、18、20、25、30、 36、40、50、60、75、90、 100、120、150、180、200
	3GN10XK (中间减速器 Decimal Gearhead)	

●减速器型号的□中为减速比的数值

Enter the gear ratio in the box (□) within the model name

■ 装有减速器时的容许转矩 Gear Motor-Torque Table

- 减速器另售·中间减速器另售。
Gearhead and mid-gearbox can be sold separately.
- 减速品型号的□中为减速比的数值。
Enter the gear ratio in the box (□) within the model name.
- □色表示与电动机同一方向运转，其他则为相反方向。
The colored background □ indicates the same rotating direction of the motor while the rotating direction of others are opposite.
- 转速是以电动机的同步转速（50Hz：1500r/min、60Hz：1800r/min）为基准除以减速比而算出来的数值。实际转速将随负载大小变化所示数值减少2%~20%左右。
The speed is calculated by dividing the motor's synchronous speed (50Hz：1500r/min、60Hz：1800r/min) by the gear ratio. The actual speed is 2%~20% less than the displayed value, depending on the size of the load.
- 希望以大于下表的减速比进行进一步减速时，可在电动机与减速机之间安装减速比为10的中间减速机。这时的容许转矩为5N·m。
To reduce the speed beyond the gear ratio in the table, attach a decimal gearhead (gear ratio:10) between the gearhead and motor. In that case, the permissible torque is 5N·m.

■ 容许力矩单位 Allowance Torque Unit：上段 Upside (N.m) /下段 Belowside (kgf.cm)

类型 Type 电动机/减速机 Motor/Gearhead	减速比 Gear Ratio		3	3.6	5	6	7.5	9	10	12.5	15	18	20	25	30	36	40	50	60	75	90	100	120	150	180	200		
	转速 Speed r/min	50Hz	60Hz	500	417	300	250	200	166	150	120	100	83	75	60	50	41	37	30	25	20	16	15	12.5	10	8.3	7.5	
3IK15RGN-A 3IK15RGN-E 3IK15RGN-C 3IK15RGN-H	3GN□K	50Hz	0.30	0.36	0.51	0.61	0.76	0.91	0.97	13.0	15.0	18.0	1.94	2.30	2.70	3.30	3.48	4.10	5.00	5.00	5.00	5.00	5.00	5.00	5.00	5.00	5.00	
		60Hz	3.06	3.67	5.20	6.22	7.75	9.28	9.90	13.2	15.3	18.3	19.8	23.4	27.5	33.7	35.5	41.8	50.0	50.0	50.0	50.0	50.0	50.0	50.0	50.0	50.0	50.0
	3GN□K	50Hz	0.26	0.31	0.43	0.51	0.64	0.77	0.80	1.10	1.30	1.50	1.64	1.90	2.30	2.80	2.88	3.50	4.20	5.00	5.00	5.00	5.00	5.00	5.00	5.00	5.00	5.00
		60Hz	2.65	3.16	4.38	5.20	6.53	7.85	8.16	11.2	13.2	15.3	16.7	19.3	23.4	28.5	29.4	35.7	42.8	50.0	50.0	50.0	50.0	50.0	50.0	50.0	50.0	50.0

■ 容许悬挂负载·容许轴向负载 To Allow The Hoisting Of The Load Allow Axial Load

电动机 (圆轴型) →215页 Motor (Round shaft) →P215
 减速机→215页 Gearhead→P215

■ 减速机的容许负载惯性惯量 J Permissible Load Inertia J For Gearhead

→215页→P215

■ 外形图 (单位 mm) Dimensions (Unit mm)

减速机附有安装用螺丝 Mounting screws are included with gearhead.

● 导线型 Lead Wiring Type

重量 Weight：电动机 Motor：1.2kg 减速机 Gearhead：0.5kg

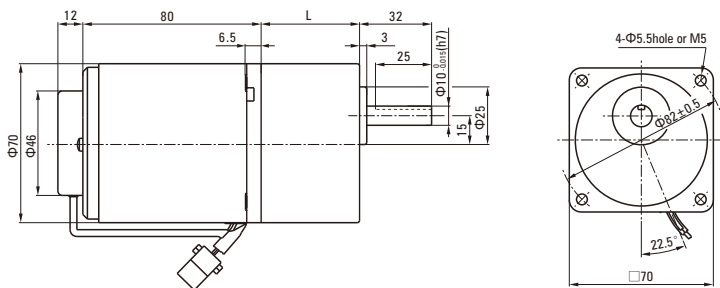

电动机型号 Motor Model	减速器型号 Gearhead Model	减速比 Gear Ratio	L1
3IK15RGN-A 3IK15RGN-E 3IK15RGN-C 3IK15RGN-H	3GN□K	3~200	42

- 减速器型号的□中为减速比的数值
Enter the gear ratio in the box (□) within the model name
- 减速比3~18可以做成长箱体 (L1=32)
Gear ratio 3~18, short case is possible (L1=32)

● 键·键槽 (减速器附件) Key · Keyway (Accessory Of Gearhead)

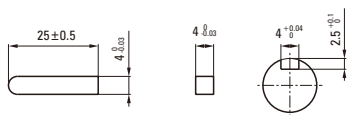

● 圆轴型的转轴部分 Shaft Section Of Round Shaft Type

除重量及轴部外电动机外形与齿轮轴型相同。
Excluding weight and the shaft section motor shape are the same as those of the pinion shaft type.

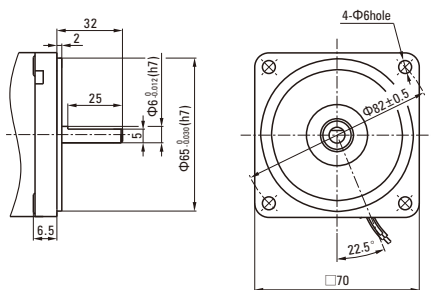

● 中间减速器 Decimal Gearhead

可安装在GN齿轮轴型上 Can be connected to GN pinion shaft type
电动机外形与齿轮轴型相同
3GN10XK
重量 Weight : 0.31kg

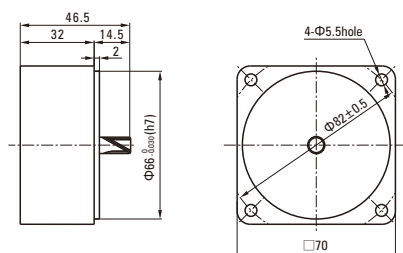

■ 连接图 Wiring Diagram

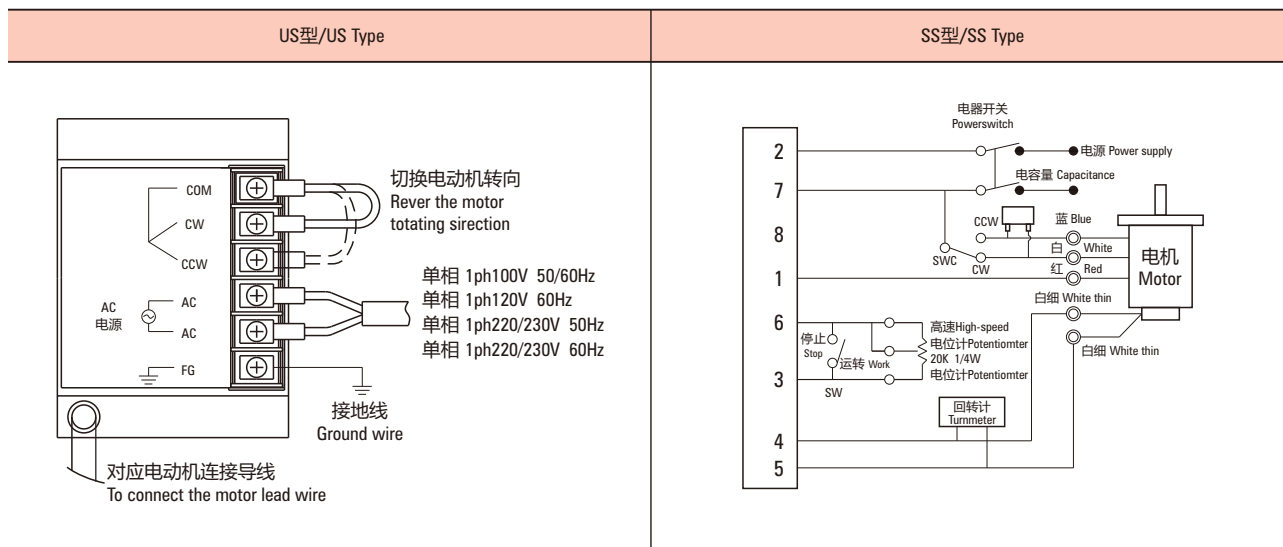

调速电动机 SPEED ADJUSTABLE MOTOR

■ 25W □ 80mm

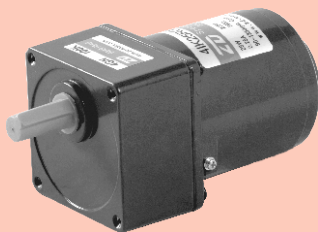

规格 Specs 连续额定 Cont. Rated

型号Model · 类型 Type 导线型 Lead Wire Type		最大 输出功率 Output power W	电压 Voltage V	频率 Frequency Hz	调速范围 Speed Control Range r/min	容许转矩 Allowance Torque		启动转矩 Starting Torque mN.m	电流 Current A	电容器容量 Capacitor μF
齿轮轴型 Pinion Shaft	圆轴型 Round Shaft					1200r/min mN.m	90r/min mN.m			
4IK25RGN-A	4IK25RA-A	25	1ph 100	50	90~1350	190	47	88	0.50	8.0
				60	90~1650				0.55	
4IK25RGN-E	4IK25RA-E	25	1ph 110	60	90~1650	190	50	105	0.45	7.0
			1ph 120						0.50	
4IK25RGN-C	4IK25RA-C	25	1ph 220	50	90~1350	190	47	88	0.25	1.8
			1ph 230						0.23	
4IK25RGN-H	4IK25RA-H	25	1ph 220	60	90~1650	190	45	88	0.23	1.8
			1ph 230							

●各种安全规格以电动机铭牌上的型号取得认证。

When the motor is approved under various safety standards, the model name on the nameplate is the approved model name.

●注：“-A”型号中电压为110V时，配置电容器容量以实际铭牌为准。

Note: "-A" it means the voltage 110V, the assembly capacitor vaule it is according the labe.

种类 Type

● 电动机 Motor

机型 Type	型号Model	
	齿轮轴型 Pinion Shaft	圆轴型 Round Shaft
导线型 Lead Wire Type	4IK25RGN-A	4IK25RA-A
	4IK25RGN-E	4IK25RA-E
	4IK25RGN-C	4IK25RA-C
	4IK25RGN-H	4IK25RA-H

● 平行轴减速器 (另售) Parallel Shaft Gearhead (Sold Separately)

减速器种类 Gearhead Type	减速器型号 Gearhead Model	减速比 Gear Ratio
长寿命●低噪音 Long Life ● Low Noise	4GN□K	3、3.6、5、6、7.5、9、10、 12.5、15、18、20、25、30、 36、40、50、60、75、90、 100、120、150、180、200
	4GN10XK (中间减速器 Decimal Gearhead)	

●减速器型号的□中为减速比的数值

Enter the gear ratio in the box (□) within the model name

■ 装有减速器时的容许转矩 Gear Motor-Torque Table

- 减速器另售·中间减速器另售。电动机型号的□中为表示带端子箱型的记号(T)。
Gearhead and mid-gearbox can be sold separately. Enter the code that represents the terminal box type (T) in the box (□) within the model name.
- 减速品型号的□中为减速比的数值。
Enter the gear ratio in the box (□) within the model name.
- □色表示与电动机同一方向旋转，其他则为相反方向。
The colored background □ indicates the same rotating direction of the motor while the rotating direction of others are opposite.
- 转速是以电动机的同步转速（50Hz：1500r/min、60Hz：1800r/min）为基准除以减速比而算出来的数值。实际转速将随负载大小变化所示数值减少2%~20%左右。
The speed is calculated by dividing the motor's synchronous speed (50Hz：1500r/min、60Hz：1800r/min) by the gear ratio. The actual speed is 2%~20% less than the displayed value, depending on the size of the load.
- 希望以大于下表的减速比进行进一步减速时，可在电动机与减速机之间安装减速比为10的中间减速机。这时的容许转矩为6N·m。
To reduce the speed beyond the gear ratio in the table, attach a decimal gearhead (gear ratio:10) between the gearhead and motor. In that case, the permissible torque is 6N·m.

■ 容许力矩单位 Allowance Torque Unit：上段 Upside (N.m) /下段 Belowside (kgf.cm)

类型 Type 电动机/减速机 Motor/Gearhead	减速比 Gear Ratio		3	3.6	5	6	7.5	9	10	12.5	15	18	20	25	30	36	40	50	60	75	90	100	120	150	180	200
	转速 Speed r/min	50Hz	500	417	300	250	200	166	150	120	100	83	75	60	50	41	37	30	25	20	16	15	12.5	10	8.3	7.5
4IK25RGN-A 4IK25RGN-E 4IK25RGN-C 4IK25RGN-H	4GN□K	50Hz	0.49	0.58	0.81	0.97	1.20	1.50	1.55	2.00	2.40	2.90	3.17	3.70	4.40	5.30	5.57	6.60	7.90	8.00	8.00	8.00	8.00	8.00	8.00	8.00
		60Hz	5.00	5.91	8.26	9.89	12.2	15.3	15.8	20.4	144	120	100	90	72	60	50	45	36	30	24	20	18	15	12	10
	60Hz	0.40	0.48	0.67	0.80	1.00	1.20	1.25	1.70	2.00	2.40	2.64	3.00	3.60	4.30	4.49	5.40	6.50	8.00	8.00	8.00	8.00	8.00	8.00	8.00	8.00
		4.08	4.89	6.83	8.16	10.2	12.2	12.8	17.3	20.4	24.4	26.9	30.6	36.7	43.8	45.8	55.1	66.3	80.0	80.0	80.0	80.0	80.0	80.0	80.0	80.0

■ 容许悬挂负载·容许轴向负载 To Allow The Hoisting Of The Load Allow Axial Load

电动机（圆轴型）→P215页

Motor (Round shaft) →P215

减速机→P215页

Gearhead→P215

■ 减速机的容许负载惯性惯量 J Permissible Load Inertia J For Gearhead

→P215页→P215

■ 外形图（单位 mm）Dimensions (Unit mm)

减速机附有安装用螺丝 Mounting screws are included with gearhead.

● 导线型 Lead Wiring Type

重量 Weight：电动机 Motor：1.7kg

减速机 Gearhead：0.8kg

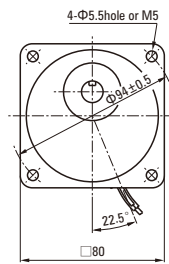
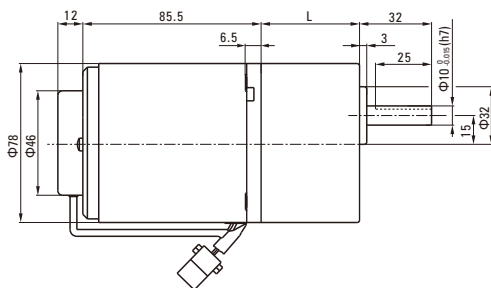

电动机型号 Motor Model	减速机型号 Gearhead Model	减速比 Gear Ratio	L1
4IK25RGN-A 4IK25RGN-E 4IK25RGN-C 4IK25RGN-H	4GN□K	3~200	43.5

- 减速机型号的□中为减速比的数值
Enter the gear ratio in the box (□) within the model name
- 减速比3~18可以做成短箱体 (L1=32)
Gear ratio 3~18, short case is possible (L1=32)

● 键·键槽 (减速器附件) Key · Keyway (Accessory Of Gearhead)

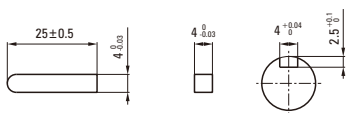

● 圆轴型的转轴部分 Shaft Section Of Round Shaft Type

除重量及轴部外电动机外形与齿轮轴型相同。
Excluding weight and the shaft section motor shape are the same as those of the pinion shaft type.

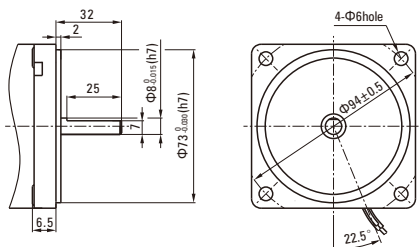

● 中间减速器 Decimal Gearhead

可安装在GN齿轮轴型上 Can be connected to GN pinion shaft type
电动机外形与齿轮轴型相同
4GN10XK
重量 Weight : 0.41kg

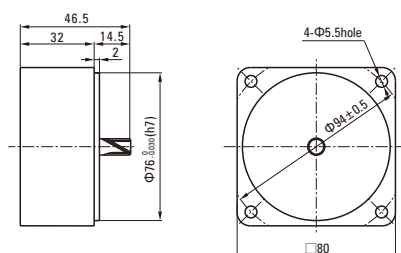

■ 连接图 Wiring Diagram

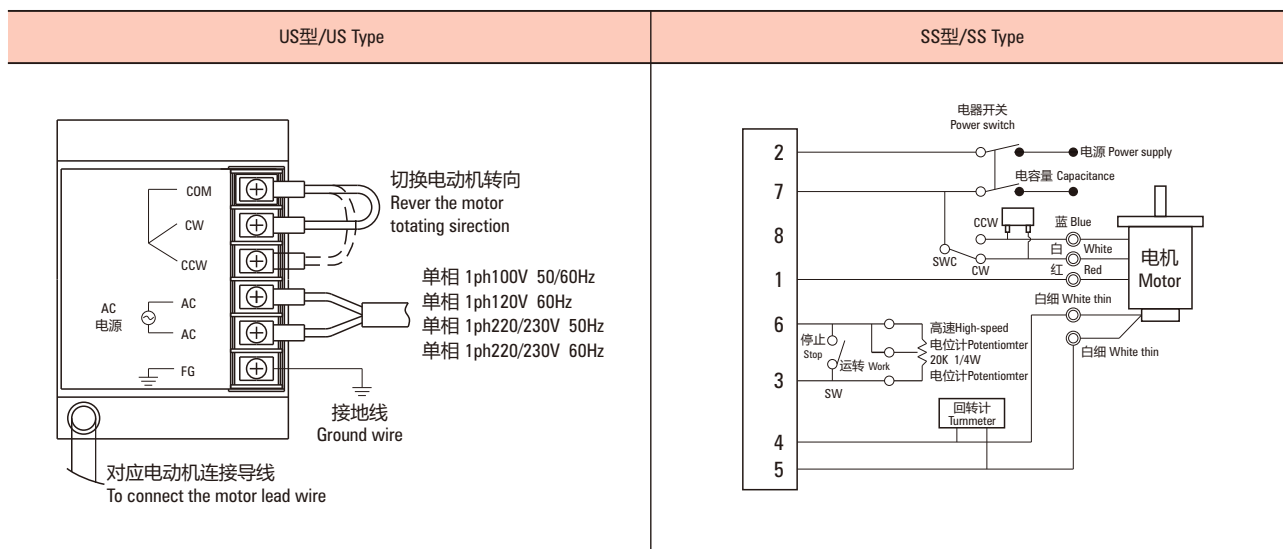

说明
Explain

感应电动机
Induction Motor

可逆电动机
Reversible Motors

刹车电动机
Brake Motors

调速电动机
Speed Control Motors

转矩电动机
Torque Motors

调速电动机 SPEED ADJUSTABLE MOTOR

■ 40W □ 90mm

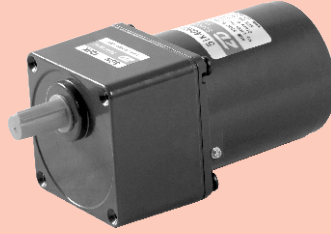

规格 Specs 连续额定 Cont. Rated

型号Model · 类型 Type 导线型 Lead Wire Type		最大 输出功率 Output power W	电压 Voltage V	频率 Frequency Hz	调速范围 Speed Control Range r/min	容许转矩 Allowance Torque		启动转矩 Starting Torque mN.m	电流 Current A	电容器容量 Capacitor μF
齿轮轴型 Pinion Shaft	圆轴型 Round Shaft					1200r/min mN.m	90r/min mN.m			
5IK40RGN-A	5IK40RA-A	40	1ph 100	50	90~1350	260	70	180	0.65	12.0
				60	90~1650				0.70	
5IK40RGN-E	5IK40RA-E	40	1ph 110	60	90~1650	260	65	180	0.55	8.0
			1ph 120						0.60	
5IK40RGN-C	5IK40RA-C	40	1ph 220	50	90~1350	300	75	160	0.35	2.5
			1ph 230						0.40	
5IK40RGN-H	5IK40RA-H	40	1ph 220	60	90~1650	230	70	145	0.35	2.5
			1ph 230						0.40	

●各种安全规格以电动机铭牌上的型号取得认证。

When the motor is approved under various safety standards, the model name on the nameplate is the approved model name.

●注：“-A”型号中电压为110V时，配置电容器容量以实际铭牌为准。

Note: "-A" it means the voltage 110V, the assembly capacitor vaule it is according the labe.

种类 Type

● 电动机 Motor

机型 Type	型号Model	
	齿轮轴型 Pinion Shaft	圆轴型 Round Shaft
导线型 Lead Wire Type	5IK40RGN-A	5IK40RA-A
	5IK40RGN-E	5IK40RA-E
	5IK40RGN-C	5IK40RA-C
	5IK40RGN-H	5IK40RA-H

● 平行轴减速器（另售） Parallel Shaft Gearhead (Sold Separately)

减速器种类 Gearhead Type	减速器型号 Gearhead Model	减速比 Gear Ratio
长寿命●低噪音 Long Life ● Low Noise	5GN□K	3、3.6、5、6、7.5、9、10、 12.5、15、18、20、25、30、 36、40、50、60、75、90、 100、120、150、180、200
	5GN10XK (中间减速器 Decimal Gearhead)	

●减速器型号的□中为减速比的数值

Enter the gear ratio in the box (□) within the model name

■ 装有减速器时的容许转矩 Gear Motor-Torque Table

- 减速器另售·中间减速器另售。电动机型号的□中为表示带端子箱型的记号(T)。
Gearhead and mid-gearbox can be sold separately. Enter the code that represents the terminal box type (T) in the box (□) within the model name.
- 减速品型号的□中为减速比的数值。
Enter the gear ratio in the box (□) within the model name.
- □色表示与电动机同一方向运转，其他则为相反方向。
The colored background □ indicates the same rotating direction of the motor while the rotating direction of others are opposite.
- 转速是以电动机的同步转速（50Hz：1500r/min、60Hz：1800r/min）为基准除以减速比而算出来的数值。实际转速将随负载大小变化所示数值减少2%~20%左右。
The speed is calculated by dividing the motor's synchronous speed (50Hz：1500r/min、60Hz：1800r/min) by the gear ratio. The actual speed is 2%~20% less than the displayed value, depending on the size of the load.
- 希望以大于下表的减速比进行进一步减速时，可在电动机与减速机之间安装减速比为10的中间减速机。这时的容许转矩为10N·m。
To reduce the speed beyond the gear ratio in the table, attach a decimal gearhead (gear ratio:10) between the gearhead and motor. In that case, the permissible torque is 10N·m.

■ 容许力矩单位 Allowance Torque Unit：上段 Upside (N.m) /下段 Belowside (kgf.cm)

类型 Type 电动机/减速机 Motor/Gearhead	减速比 Gear Ratio		3	3.6	5	6	7.5	9	10	12.5	15	18	20	25	30	36	40	50	60	75	90	100	120	150	180	200		
	转速 Speed r/min	50Hz	60Hz	500	417	300	250	200	166	150	120	100	83	75	60	50	41	37	30	25	20	16	15	12.5	10	8.3	7.5	
5IK40RGN-A 5IK40RGN-E 5IK40RGN-C 5IK40RGN-H	5GN□K	50Hz	0.77	0.92	1.30	1.50	1.90	2.30	2.38	3.20	3.80	4.60	4.88	5.70	6.90	8.30	8.57	10.0	10.0	10.0	10.0	10.0	10.0	10.0	10.0	10.0	10.0	
			7.85	9.38	13.2	15.3	19.4	23.4	24.3	32.6	38.7	46.9	49.8	58.1	70.4	84.7	87.4	100	100	100	100	100	100	100	100	100	100	100
		60Hz	0.63	0.76	1.10	1.30	1.60	1.90	2.00	2.60	3.20	3.80	4.07	4.70	5.70	6.80	7.19	8.60	10.0	10.0	10.0	10.0	10.0	10.0	10.0	10.0	10.0	10.0
			6.42	7.75	11.2	13.2	16.3	19.3	20.4	26.5	32.6	38.7	41.5	47.9	58.1	69.3	73.4	87.7	100	100	100	100	100	100	100	100	100	100

■ 容许悬挂负载·容许轴向负载 To Allow The Hoisting Of The Load Allow Axial Load

电动机（圆轴型）→215页 Motor (Round shaft) →P215
 减速机→215页 Gearhead→P215

■ 减速机的容许负载惯性惯量 J Permissible Load Inertia J For Gearhead

→215页→P215

■ 外形图（单位 mm）Dimensions (Unit mm)

减速机附有安装用螺丝 Mounting screws are included with gearhead.

● 导线型 Lead Wiring Type

重量 Weight：电动机 Motor：2.5kg 减速机 Gearhead：1.35kg

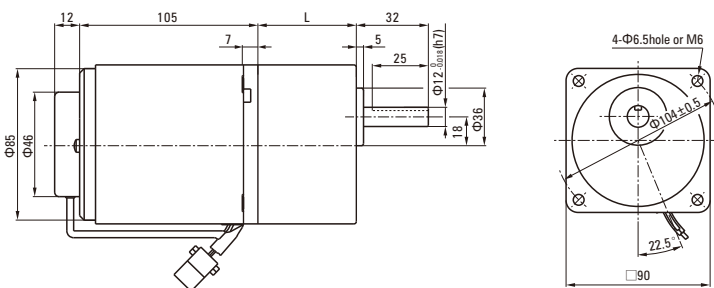

电动机型号 Motor Model	减速器型号 Gearhead Model	减速比 Gear Ratio	L1
5IK40RGN-A 5IK40RGN-E 5IK40RGN-C 5IK40RGN-H	5GN□K	3~200	60

- 减速器型号的□中为减速比的数值
Enter the gear ratio in the box (□) within the model name
- 减速比3~18可以做成长箱体 (L1=42)
Gear ratio 3~18, short case is possible (L1=42)

● 键·键槽 (减速器附件) Key · Keyway (Accessory Of Gearhead)

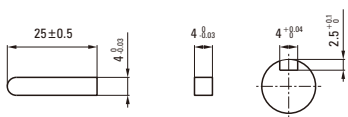

● 圆轴型的转轴部分 Shaft Section Of Round Shaft Type

除重量及轴部外电动机外形与齿轮轴型相同。
Excluding weight and the shaft section motor shape are the same as those of the pinion shaft type.

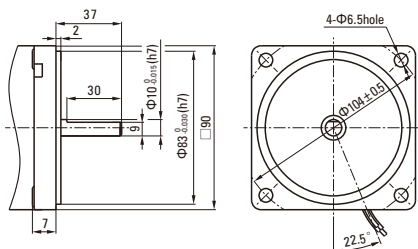

● 中间减速器 Decimal Gearhead

可安装在GN齿轮轴型上 Can be connected to GN pinion shaft type
电动机外形与齿轮轴型相同
5GN10XK
重量 Weight : 0.6kg

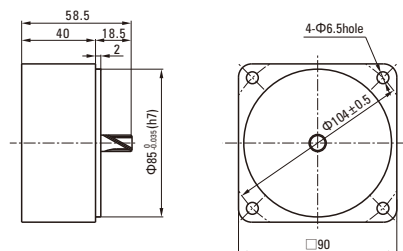

■ 连接图 Wiring Diagram

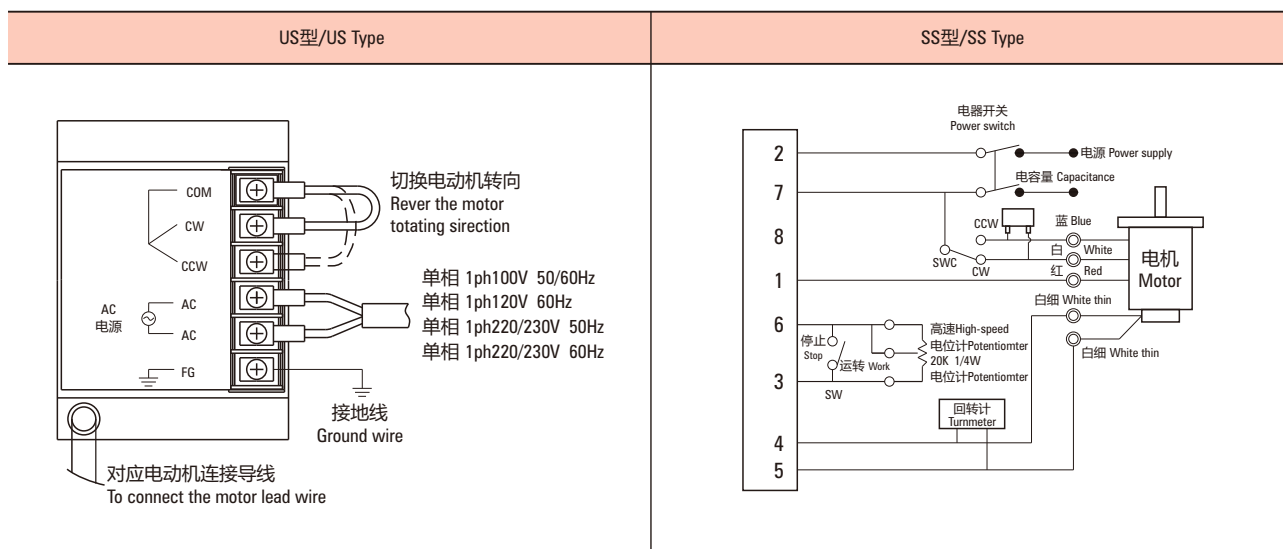

调速电动机 SPEED ADJUSTABLE MOTOR

■ 60W □ 90mm

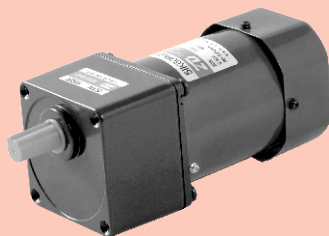

规格 Specs 连续额定 Cont. Rated

型号Model · 类型 Type 导线型 Lead Wire Type		最大 输出功率 Output power W	电压 Voltage V	频率 Frequency Hz	调速范围 Speed Control Range r/min	容许转矩 Allowance Torque		启动转矩 Starting Torque mN.m	电流 Current A	电容器容量 Capacitor μF
齿轮轴型 Pinion Shaft	圆轴型 Round Shaft					1200r/min mN.m	90r/min mN.m			
5IK60RGN-AF	5IK60RA-AF	60	1ph 100	50	90~1350	460	140	265	1.00	20.0
				60	90~1650	490	160		1.10	
5IK60RGN-EF	5IK60RA-EF	60	1ph 110	60	90~1650	490	160	265	0.80	12.0
			1ph 120						0.85	
5IK60RGN-CF	5IK60RA-CF	60	1ph 220	50	90~1350	490	140	265	0.50	4.0
			1ph 230						0.55	
5IK60RGN-HF	5IK60RA-HF	60	1ph 220	60	90~1650	490	160	265	0.50	4.0
			1ph 230						0.55	

●各种安全规格以电动机铭牌上的型号取得认证。

When the motor is approved under various safety standards, the model name on the nameplate is the approved model name.

●注：“-A”型号中电压为110V时，配置电容器容量以实际铭牌为准。

Note: "-A" it means the voltage 110V, the assembly capacitor vaule it is according the labe.

种类 Type

● 电动机 Motor

机型 Type	型号Model	
	齿轮轴型 Pinion Shaft	圆轴型 Round Shaft
导线型 Lead Wire Type	5IK60RGN-AF	5IK60RA-AF
	5IK60RGN-EF	5IK60RA-EF
	5IK60RGN-CF	5IK60RA-CF
	5IK60RGN-HF	5IK60RA-HF

● 平行轴减速器（另售）Parallel Shaft Gearhead (Sold Separately)

减速器种类 Gearhead Type	减速器型号 Gearhead Model	减速比 Gear Ratio
长寿命●低噪音 Long Life ● Low Noise	5GN□K	3、3.6、5、6、7.5、9、10、 12.5、15、18、20、25、30、 36、40、50、60、75、90、 100、120、150、180、200
	5GN10XK (中间减速器 Decimal Gearhead)	

●减速器型号的□中为减速比的数值

Enter the gear ratio in the box (□) within the model name

■ 装有减速器时的容许转矩 Gear Motor-Torque Table

- 减速器另售·中间减速器另售。
Gearhead and mid-gearbox can be sold separately.
- 减速品型号的□中为减速比的数值。
Enter the gear ratio in the box (□) within the model name.
- □色表示与电动机同一方向运转，其他则为相反方向。
The colored background □ indicates the same rotating direction of the motor while the rotating direction of others are opposite.
- 转速是以电动机的同步转速（50Hz：1500r/min、60Hz：1800r/min）为基准除以减速比而算出来的数值。实际转速将随负载大小变化所示数值减少2%~20%左右。
The speed is calculated by dividing the motor's synchronous speed (50Hz：1500r/min、60Hz：1800r/min) by the gear ratio. The actual speed is 2%~20% less than the displayed value, depending on the size of the load.
- 希望以大于下表的减速比进行进一步减速时，可在电动机与减速机之间安装减速比为10的中间减速器。这时的容许转矩为10N·m。
To reduce the speed beyond the gear ratio in the table, attach a decimal gearhead (gear ratio:10) between the gearhead and motor. In that case, the permissible torque is 10N·m.

■ 容许力矩单位 Allowance Torque Unit：上段 Upside (N.m) /下段 Belowside (kgf.cm)

类型 Type 电动机/减速机 Motor/Gearhead	减速比 Gear Ratio		3	3.6	5	6	7.5	9	10	12.5	15	18	20	25	30	36	40	50	60	75	90	100	120	150	180	200	
	转速 Speed r/min	50Hz	500	417	300	250	200	166	150	120	100	83	75	60	50	41	37	30	25	20	16	15	12.5	10	8.3	7.5	
		60Hz	600	500	360	300	240	200	180	144	120	100	90	72	60	50	45	36	30	24	20	18	15	12	10	9	
5IK60RGN-A 5IK60RGN-E 5IK60RGN-C 5IK60RGN-H	5GN□K	50Hz	1.10	1.40	1.90	2.30	2.90	3.40	3.57	4.80	5.70	6.80	7.03	8.60	10.0	10.0	10.0	10.0	10.0	10.0	10.0	10.0	10.0	10.0	10.0	10.0	
			11.2	14.2	19.3	23.4	29.6	34.7	36.4	48.9	58.1	69.3	71.7	87.7	100	100	100	100	100	100	100	100	100	100	100	100	
		60Hz	0.92	1.10	1.50	1.80	2.30	2.80	2.99	3.80	4.60	5.50	5.70	6.90	8.30	10.0	10.0	10.0	10.0	10.0	10.0	10.0	10.0	10.0	10.0	10.0	10.0
			9.38	11.2	15.3	18.3	23.4	28.5	30.5	38.7	46.9	56.1	58.2	70.1	84.7	100	100	100	100	100	100	100	100	100	100	100	100

■ 容许悬挂负载·容许轴向负载 To Allow The Hoisting Of The Load Allow Axial Load

电动机（圆轴型）→P215页

Motor (Round shaft) →P215

减速机→P215页

Gearhead→P215

■ 减速机的容许负载惯性惯量 J Permissible Load Inertia J For Gearhead

→P215页→P215

■ 外形图（单位 mm）Dimensions (Unit mm)

减速机附有安装用螺丝 Mounting screws are included with gearhead.

● 导线型 Lead Wiring Type

重量 Weight：电动机 Motor：2.8kg

减速机 Gearhead：1.35kg

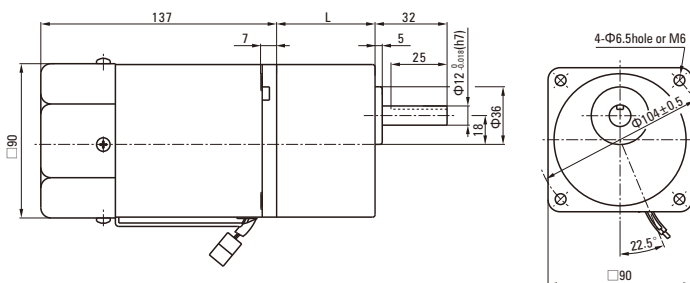

电动机型号 Motor Model	减速机型号 Gearhead Model	减速比 Gear Ratio	L1
5IK60RGN-A 5IK60RGN-E 5IK60RGN-C 5IK60RGN-H	5GN□K	3~200	60

- 减速机型号的□中为减速比的数值
Enter the gear ratio in the box (□) within the model name
- 减速比3~18可以做成短箱体 (L1=42)
Gear ratio 3~18, short case is possible (L1=42)

● 键·键槽 (减速器附件) Key · Keyway (Accessory Of Gearhead)

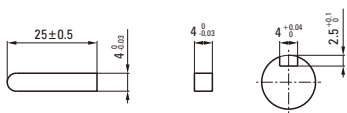

● 圆轴型的转轴部分 Shaft Section Of Round Shaft Type

除重量及轴部外电动机外形与齿轮轴型相同。
Excluding weight and the shaft section motor shape are the same as those of the pinion shaft type.

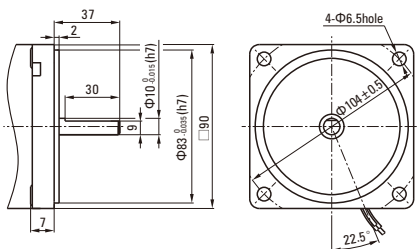

● 中间减速器 Decimal Gearhead

可安装在GN齿轮轴型上 Can be connected to GN pinion shaft type
电动机外形与齿轮轴型相同
5GN10XK
重量 Weight : 0.6kg

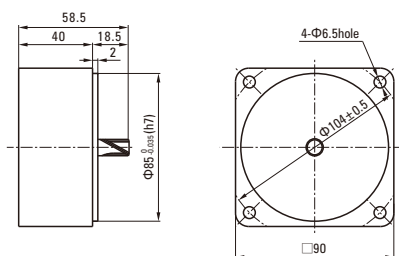

■ 连接图 Wiring Diagram

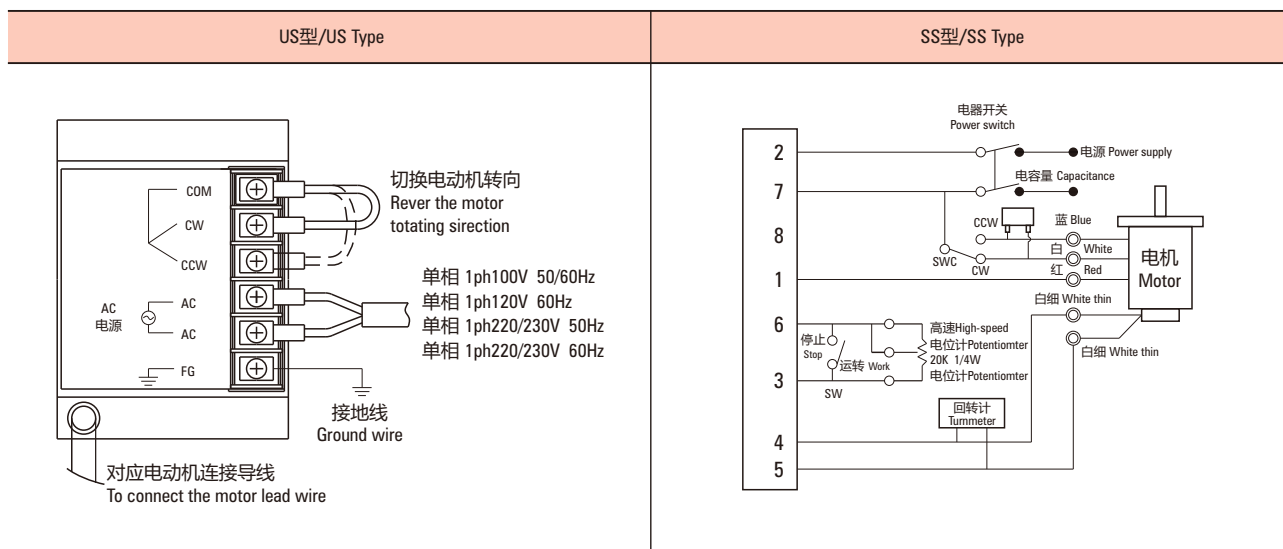

说明 Explain

感应电动机 Induction Motor

可逆电动机 Reversible Motors

刹车电动机 Brake Motors

调速电动机 Speed Control Motors

转矩电动机 Torque Motors

调速电动机 SPEED ADJUSTABLE MOTOR

■ 60W □ 90mm

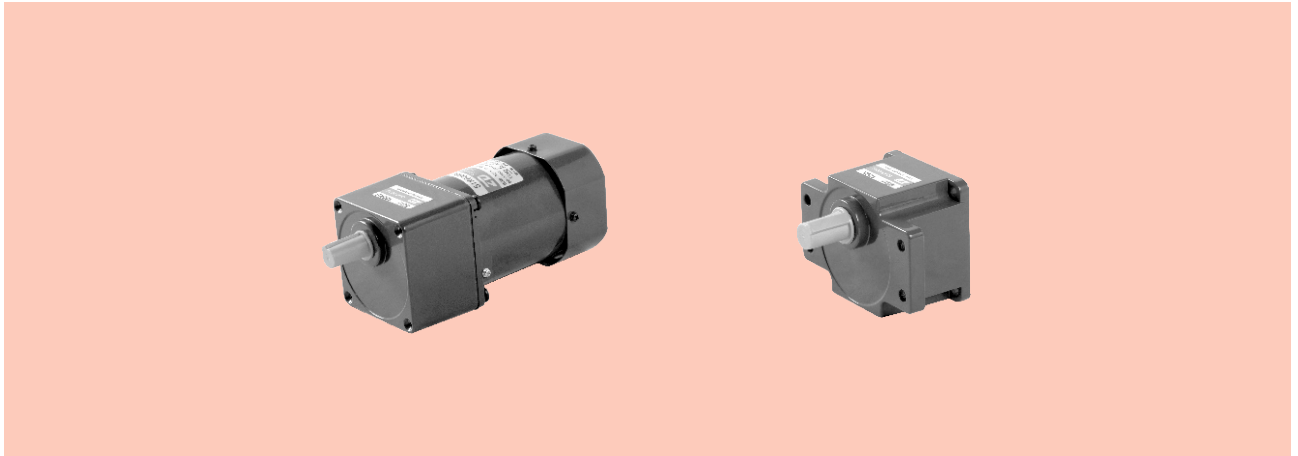

规格 Specs 连续额定 Cont. Rated

型号Model · 类型 Type 导线型 Lead Wire Type	最大 输出功率 Output power W	电压 Voltage V	频率 Frequency Hz	调速范围 Speed Control Range r/min	容许转矩 Allowance Torque		启动转矩 Starting Torque mN.m	电流 Current A	电容器容量 Capacitor μF
					1200r/min mN.m	90r/min mN.m			
5IK60RGU-AF 齿轮轴型 Pinion Shaft	60	1ph 100	50	90~1350	460	140	265	1.00	20.0
			60	90~1650	490	160		1.10	
5IK60RGU-EF	60	1ph 110	60	90~1650	490	160	265	0.80	12.0
		1ph 120						0.85	
5IK60RGU-CF	60	1ph 220	50	90~1350	490	140	265	0.50	4.0
		1ph 230						0.55	
5IK60RGU-HF	60	1ph 220	60	90~1650	490	160	265	0.50	4.0
		1ph 230						0.55	

●各种安全规格以电动机铭牌上的型号取得认证。

When the motor is approved under various safety standards, the model name on the nameplate is the approved model name.

●注：“-A”型号中电压为110V时，配置电容器容量以实际铭牌为准。

Note: "-A" it means the voltage 110V, the assembly capacitor vaule it is according the labe.

种类 Type

● 电动机 Motor

机型 Type	型号Model
	导线型 Lead Wire Type

● 平行轴减速器（另售） Parallel Shaft Gearhead (Sold Separately)

减速器种类 Gearhead Type	减速器型号 Gearhead Model	减速比 Gear Ratio
长寿命●低噪音 Long Life ● Low Noise	5GU□KB	3、3.6、5、6、7.5、9、10、 12.5、15、18、20、25、30、 36、40、50、60、75、90、 100、120、150、180、200
	5GU10XK (中间减速器 Decimal Gearhead)	

●减速器型号的□中为减速比的数值

Enter the gear ratio in the box (□) within the model name

■ 装有减速器时的容许转矩 Gear Motor-Torque Table

- 减速器另售·中间减速器另售。电动机型号的□中为表示带端子箱型的记号(T)。
Gearhead and mid-gearbox can be sold separately. Enter the code that represents the terminal box type (T) in the box (□) within the model name.
- 减速品型号的□中为减速比的数值。
Enter the gear ratio in the box (□) within the model name.
- □色表示与电动机同一方向运转，其他则为相反方向。
The colored background □ indicates the same rotating direction of the motor while the rotating direction of others are opposite.
- 转速是以电动机的同步转速（50Hz：1500r/min、60Hz：1800r/min）为基准除以减速比而算出来的数值。实际转速将随负载大小变化所示数值减少2%~20%左右。
The speed is calculated by dividing the motor's synchronous speed (50Hz：1500r/min、60Hz：1800r/min) by the gear ratio. The actual speed is 2%~20% less than the displayed value, depending on the size of the load.
- 希望以大于下表的减速比进行进一步减速时，可在电动机与减速机之间安装减速比为10的中间减速机。这时的容许转矩为20N·m。
To reduce the speed beyond the gear ratio in the table, attach a decimal gearhead (gear ratio:10) between the gearhead and motor. In that case, the permissible torque is 20N·m.

■ 容许力矩单位 Allowance Torque Unit：上段 Upside (N.m) /下段 Belowside (kgf.cm)

类型 Type 电动机/减速机 Motor/Gearhead	减速比 Gear Ratio		3	3.6	5	6	7.5	9	10	12.5	15	18	20	25	30	36	40	50	60	75	90	100	120	150	180	200
	转速 Speed r/min	50Hz	500	417	300	250	200	166	150	120	100	83	75	60	50	41	37	30	25	20	16	15	12.5	10	8.3	7.5
		60Hz	600	500	360	300	240	200	180	144	120	100	90	72	60	50	45	36	30	24	20	18	15	12	10	9
5IK60RGU-AF 5IK60RGU-EF 5IK60RGU-CF 5IK60RGU-HF	5GU□KB	50Hz	1.10	1.40	1.90	2.30	2.90	3.40	3.61	4.80	5.70	6.80	7.12	8.60	10.0	10.3	11.6	12.4	15.5	18.6	20.0	20.0	20.0	20.0	20.0	20.0
		60Hz	0.92	1.10	1.50	1.80	2.30	2.80	3.01	3.80	4.60	5.50	5.73	6.90	8.30	83.0	9.70	10.0	12.5	15.0	18.8	20.0	20.0	20.0	20.0	20.0
	5GU□K	50Hz	11.2	14.2	19.3	23.4	29.6	34.7	36.8	48.9	58.1	69.3	72.6	87.7	100	105	118	126	158	189	200	200	200	200	200	200
		60Hz	9.38	11.2	15.3	18.3	23.4	28.5	30.7	38.7	46.9	56.1	58.4	70.1	84.7	84.6	98.9	102	127	153	192	200	200	200	200	200

■ 容许悬挂负载·容许轴向负载 To Allow The Hoisting Of The Load Allow Axial Load

电动机 (圆轴型) →215页 Motor (Round shaft) →P215
 减速机→215页 Gearhead→P215

■ 减速机的容许负载惯性惯量 J Permissible Load Inertia J For Gearhead

→215页→P215

■ 外形图 (单位 mm) Dimensions (Unit mm)

减速机附有安装用螺丝 Mounting screws are included with gearhead.

● 导线型 Lead Wiring Type

重量 Weight：电动机 Motor：2.8kg 减速机 Gearhead：1.5kg

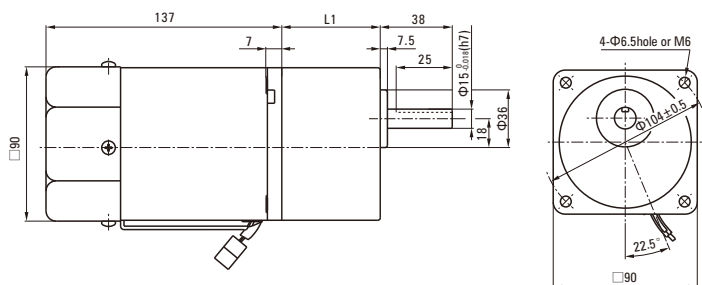

电动机型号 Motor Model	减速器型号 Gearhead Model	减速比 Gear Ratio	L1
5IK60RGU-AF 5IK60RGU-EF 5IK60RGU-CF 5IK60RGU-HF	5GU□KB	3~200	65.5

- 减速器型号的□中为减速比的数值
Enter the gear ratio in the box (□) within the model name

● 凸缘安装型减速器 Flange Mounting Reducer

可安装在GU齿轮轴型上
Can be mounted on GU type gear shaft
5GU□K
重量Weight:1.5kg

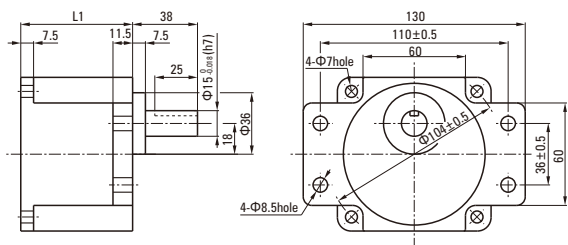

● 键·键槽 (减速器附件)

Key · Keyway (Accessory of Gearhead)

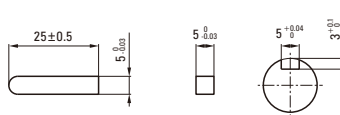

● 圆轴型的转轴部分 Shaft Section Of Round Shaft Type

除重量及轴部外电动机外形与齿轮轴型相同。
Excluding weight and the shaft section motor shape are the same as those of the pinion shaft type.

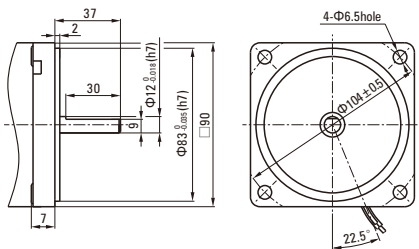

● 中间减速器 Decimal Gearhead

可安装在GU齿轮轴型上 Can be connected to GU pinion shaft type
电动机外形与齿轮轴型相同
5GU10XK
重量 Weight : 0.65kg

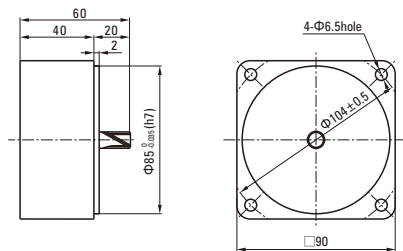

■ 连接图 Wiring Diagram

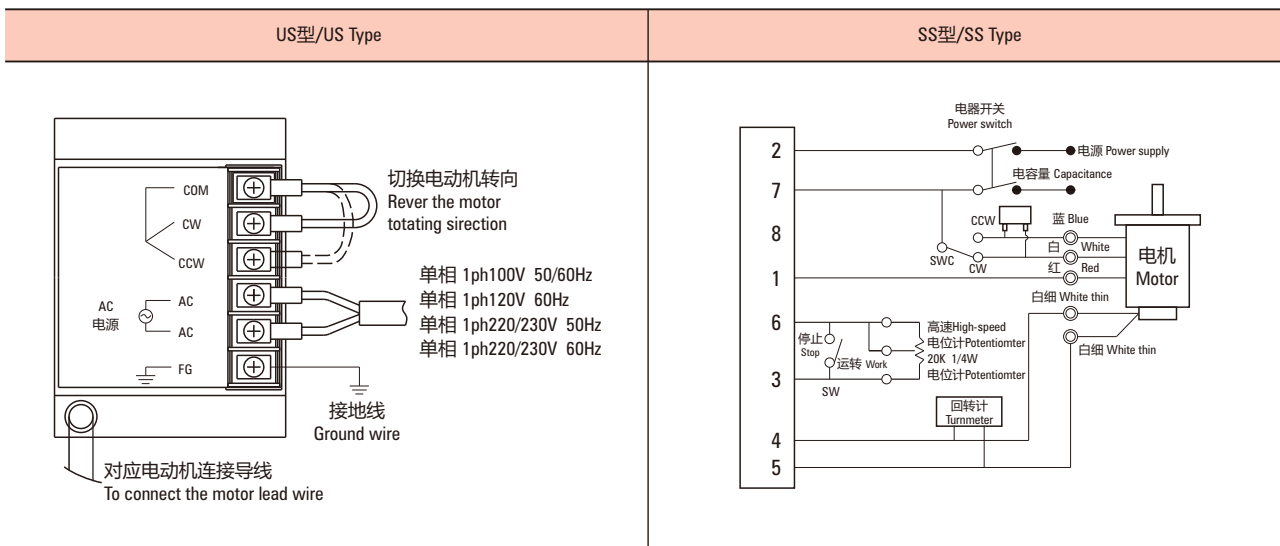

调速电动机 SPEED ADJUSTABLE MOTOR

■ 90W □ 90mm

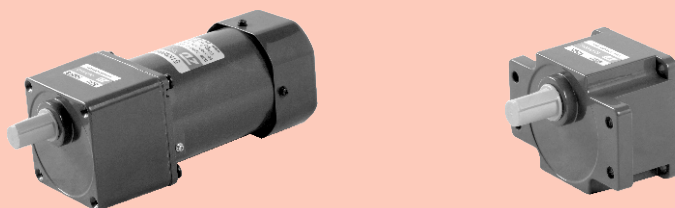

规格 Specs 连续额定 Cont. Rated

型号Model · 类型 Type 导线型 Lead Wire Type		最大 输出功率 Output power W	电压 Voltage V	频率 Frequency Hz	调速范围 Speed Control Range r/min	容许转矩 Allowance Torque		启动转矩 Starting Torque mN.m	电流 Current A	电容器容量 Capacitor μF
齿轮轴型 Pinion Shaft	圆轴型 Round Shaft					1200r/min mN.m	90r/min mN.m			
5IK90RGU-AF	5IK90RA-AF	90	1ph 100	50	90~1350	710	230	405	1.55	25.0
				60	90~1650		260		1.85	
5IK90RGU-EF	5IK90RA-EF	90	1ph 110	60	90~1650	710	260	410	1.40	20.0
			1ph 120						1.45	
5IK90RGU-CF	5IK90RA-CF	90	1ph 220	50	90~1350	710	230	410	0.72	5.0
			1ph 230						0.70	
5IK90RGU-HF	5IK90RA-HF	90	1ph 220	60	90~1650	710	260	410	0.71	5.0
			1ph 230						0.75	

●各种安全规格以电动机铭牌上的型号取得认证。

When the motor is approved under various safety standards, the model name on the nameplate is the approved model name.

●注：“-A”型号中电压为110V时，配置电容器容量以实际铭牌为准。

Note: "-A" it means the voltage 110V, the assembly capacitor vaule it is according the labe.

种类 Type

● 电动机 Motor

机型 Type	型号Model	
	齿轮轴型 Pinion Shaft	圆轴型 Round Shaft
导线型 Lead Wire Type	5IK90RGU-AF	5IK90RA-AF
	5IK90RGU-EF	5IK90RA-EF
	5IK90RGU-CF	5IK90RA-CF
	5IK90RGU-HF	5IK90RA-HF

● 平行轴减速器（另售）Parallel Shaft Gearhead (Sold Separately)

减速器种类 Gearhead Type	减速器型号 Gearhead Model	减速比 Gear Ratio
长寿命●低噪音 Long Life ● Low Noise	5GU□K	3、3.6、5、6、7.5、9、10、 12.5、15、18、20、25、30、 36、40、50、60、75、90、 100、120、150、180、200
	5GU10XK (中间减速器 Decimal Gearhead)	

●减速器型号的□中为减速比的数值

Enter the gear ratio in the box (□) within the model name

■ 装有减速器时的容许转矩 Gear Motor-Torque Table

- 减速器另售·中间减速器另售。电动机型号的□中为表示带端子箱型的记号(T)。
Gearhead and mid-gearbox can be sold separately. Enter the code that represents the terminal box type (T) in the box (□) within the model name.
- 减速品型号的□中为减速比的数值。
Enter the gear ratio in the box (□) within the model name.
- □色表示与电动机同一方向运转，其他则为相反方向。
The colored background □ indicates the same rotating direction of the motor while the rotating direction of others are opposite.
- 转速是以电动机的同步转速（50Hz：1500r/min、60Hz：1800r/min）为基准除以减速比而算出来的数值。实际转速将随负载大小变化所示数值减少2%~20%左右。
The speed is calculated by dividing the motor's synchronous speed (50Hz：1500r/min、60Hz：1800r/min) by the gear ratio. The actual speed is 2%~20% less than the displayed value, depending on the size of the load.
- 希望以大于下表的减速比进行进一步减速时，可在电动机与减速机之间安装减速比为10的中间减速机。
这时的容许转矩为20N·m。
To reduce the speed beyond the gear ratio in the table, attach a decimal gearhead (gear ratio:10) between the gearhead and motor. In that case, the permissible torque is 20N·m.

■ 容许力矩单位 Allowance Torque Unit：上段 Upside (N.m) /下段 Belowside (kgf.cm)

类型 Type 电动机/减速机 Motor/Gearhead	减速比 Gear Ratio		3	3.6	5	6	7.5	9	10	12.5	15	18	20	25	30	36	40	50	60	75	90	100	120	150	180	200		
	转速 Speed r/min	50Hz	60Hz	50Hz	60Hz	50Hz	60Hz	50Hz	60Hz	50Hz	60Hz	50Hz	60Hz	50Hz	60Hz	50Hz	60Hz	50Hz	60Hz	50Hz	60Hz	50Hz	60Hz	50Hz	60Hz	50Hz	60Hz	
5IK90RGU-AF□ 5IK90RGU-EF□ 5IK90RGU-CF□ 5IK90RGU-HF□	5GU□KB 5GU□K	50Hz	1.70	2.00	2.80	3.40	4.30	5.10	5.31	6.40	7.70	9.20	9.55	11.6	13.6	16.6	18.1	20.0	20.0	20.0	20.0	20.0	20.0	20.0	20.0	20.0	20.0	
			17.3	20.4	28.6	34.7	43.9	52.0	54.2	65.3	78.6	93.3	97.4	118	139	169	184	200	200	200	200	200	200	200	200	200	200	200
		60Hz	1.40	1.70	2.50	2.80	3.50	4.20	4.43	5.20	6.20	7.50	7.81	9.40	11.3	13.5	14.5	18.8	20.0	20.0	20.0	20.0	20.0	20.0	20.0	20.0	20.0	20.0
			14.3	17.3	25.5	28.6	35.7	42.9	45.2	53.1	63.3	76.5	79.6	95.9	115	138	148	19.2	200	200	200	200	200	200	200	200	200	200

■ 容许悬挂负载·容许轴向负载 To Allow The Hoisting Of The Load Allow Axial Load

电动机（圆轴型）→P215页

Motor (Round shaft) →P215

减速机→P215页

Gearhead→P215

■ 减速机的容许负载惯性惯量 J Permissible Load Inertia J For Gearhead

→P215页→P215

■ 外形图（单位 mm）Dimensions (Unit mm)

减速机附有安装用螺丝 Mounting screws are included with gearhead.

● 导线型 Lead Wiring Type

重量 Weight：电动机 Motor：3.3kg

减速机 Gearhead：1.5kg

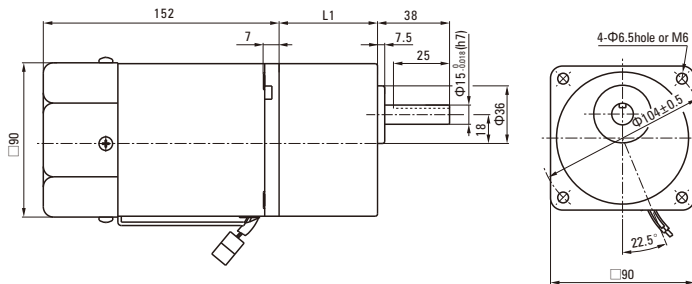

电动机型号 Motor Model	减速机型号 Gearhead Model	减速比 Gear Ratio	L1
5IK90RGU-AF 5IK90RGU-EF 5IK90RGU-CF 5IK90RGU-HF	5GU□KB	3~200	65.5

- 减速机型号的□中为减速比的数值
Enter the gear ratio in the box (□) within the model name

● 凸缘安装型减速器 Flange Mounting Reducer

可安装在GU齿轮轴型上
Can be mounted on GU type gear shaft
5GU□K
重量Weight:1.5kg

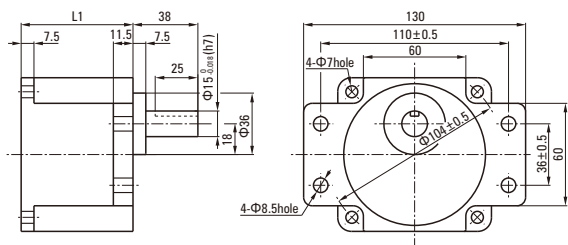

● 键·键槽 (减速器附件)

Key · Keyway (Accessory of Gearhead)

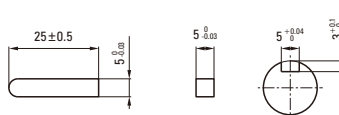

● 圆轴型的转轴部分 Shaft Section Of Round Shaft Type

除重量及轴部外电动机外形与齿轮轴型相同。
Excluding weight and the shaft section motor shape are the same as those of the pinion shaft type.

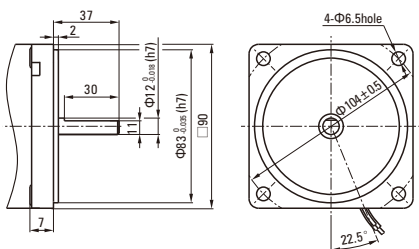

● 中间减速器 Decimal Gearhead

可安装在GU齿轮轴型上 Can be connected to GU pinion shaft type
电动机外形与齿轮轴型相同
5GU10XK
重量 Weight : 0.65kg

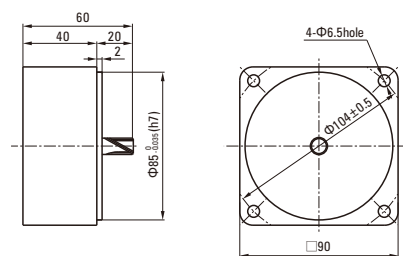

说明

感应电动机
Induction Motor

可逆电动机
Reversible Motors

■ 连接图 Wiring Diagram

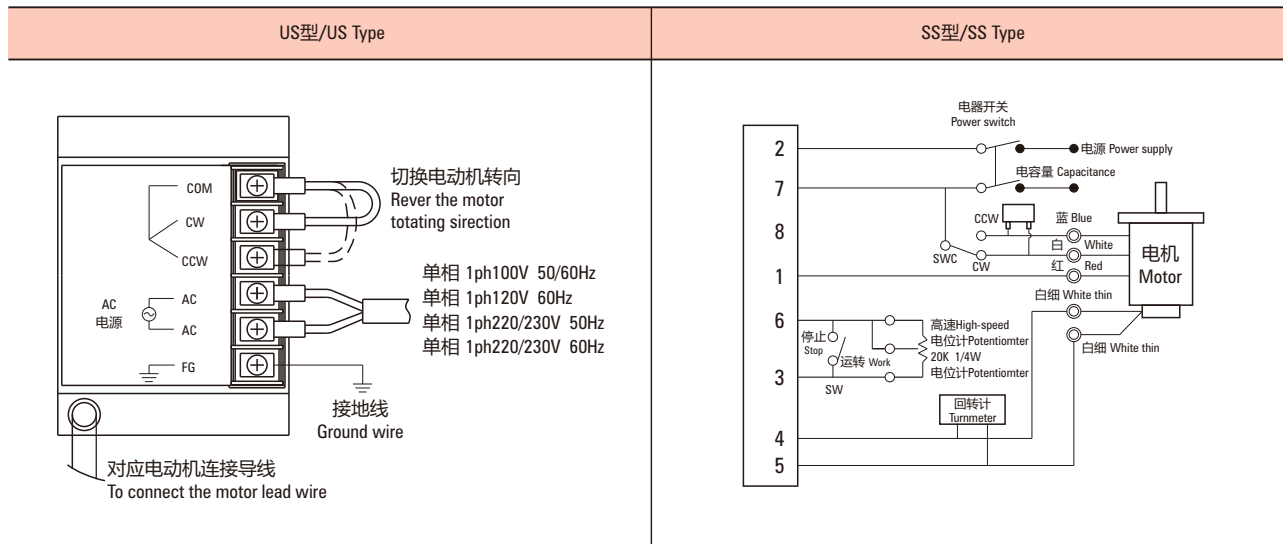

刹车电动机
Brake Motors

调速电动机
Speed Control Motors

转矩电动机
Torque Motors

调速电动机 SPEED ADJUSTABLE MOTOR

■ 120W □ 90mm

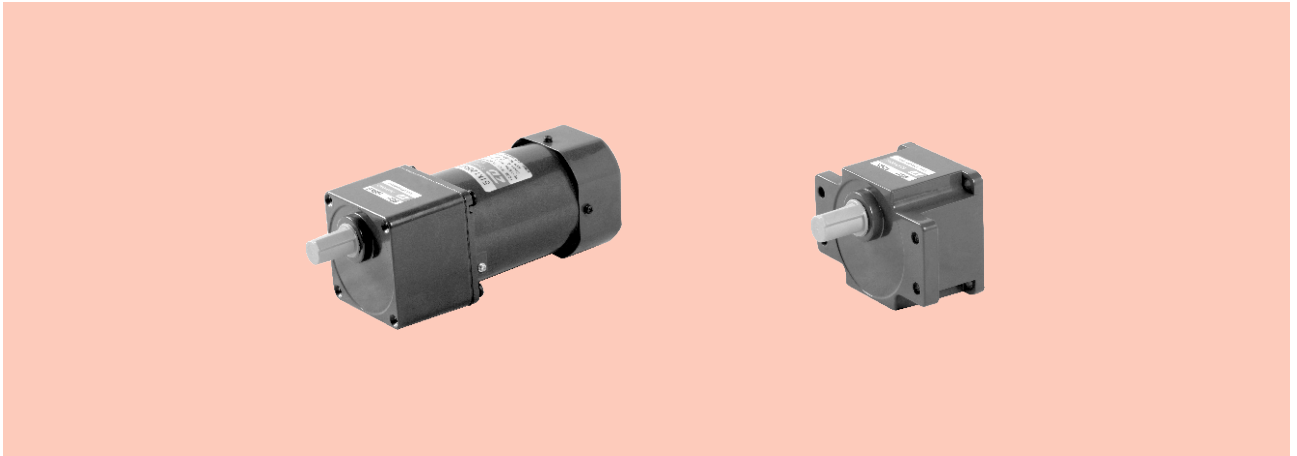

规格 Specs 连续额定 Cont. Rated

型号 Model · 类型 Type 导线型 Lead Wire Type		最大输出功率 Output power W	电压 Voltage V	频率 Frequency Hz	调速范围 Speed Control Range r/min	容许转矩 Allowance Torque		启动转矩 Starting Torque mN.m	电流 Current A	电容器容量 Capacitor μF
齿轮轴型 Pinion Shaft	圆轴型 Round Shaft					1200r/min mN.m	90r/min mN.m			
5IK120RGU-AF	5IK120RA-AF	120	1ph 100	50	90~1350	750	330	530	2.10	30.0
				60	90~1650				2.50	
5IK120RGU-EF	5IK120RA-EF	120	1ph 110	60	90~1650	750	360	530	1.65	25.0
			1ph 120						1.80	
5IK120RGU-CF	5IK120RA-CF	120	1ph 220	50	90~1350	750	330	530	1.00	7.0
			1ph 230						0.95	
5IK120RGU-HF	5IK120RA-HF	120	1ph 220	60	90~1650	750	360	530	1.00	7.0
			1ph 230						0.95	

●各种安全规格以电动机铭牌上的型号取得认证。

When the motor is approved under various safety standards, the model name on the nameplate is the approved model name.

●注：“-A”型号中电压为110V时，配置电容器容量以实际铭牌为准。

Note: "-A" it means the voltage 110V, the assembly capacitor vaule it is according the labe.

种类 Type

● 电动机 Motor

机型 Type	型号 Model	
	齿轮轴型 Pinion Shaft	圆轴型 Round Shaft
导线型 Lead Wire Type	5IK120RGU-AF	5IK120RA-AF
	5IK120RGU-EF	5IK120RA-EF
	5IK120RGU-CF	5IK120RA-CF
	5IK120RGU-HF	5IK120RA-HF

● 平行轴减速器（另售） Parallel Shaft Gearhead (Sold Separately)

减速器种类 Gearhead Type	减速器型号 Gearhead Model	减速比 Gear Ratio
长寿命●低噪音 Long Life ● Low Noise	5GU□KB	3、3.6、5、6、7.5、9、10、12.5、15、18、20、25、30、36、40、50、60、75、90、100、120、150、180、200
	5GU10XK (中间减速器 Decimal Gearhead)	

●减速器型号的□中为减速比的数值

Enter the gear ratio in the box (□) within the model name

■ 装有减速器时的容许转矩 Gear Motor-Torque Table

- 减速器另售·中间减速器另售。电动机型号的□中为表示带端子箱型的记号(T)。
Gearhead and mid-gearbox can be sold separately. Enter the code that represents the terminal box type (T) in the box (□) within the model name.
- 减速品型号的□中为减速比的数值。
Enter the gear ratio in the box(□) within the model name.
- □色表示与电动机同一方向运转，其他则为相反方向。
The colored background □ indicates the same rotating direction of the motor while the rotating direction of others are opposite.
- 转速是以电动机的同步转速（50Hz：1500r/min、60Hz：1800r/min）为基准除以减速比而算出来的数值。实际转速将随负载大小变化所示数值减少2%~20%左右。
The speed is calculated by dividing the motor's synchronous speed (50Hz：1500r/min、60Hz：1800r/min) by the gear ratio. The actual speed is 2%~20% less than the displayed value, depending on the size of the load.
- 希望以大于下表的减速比进行进一步减速时，可在电动机与减速器之间安装减速比为10的中间减速器。这时的容许转矩为20N·m。
To reduce the speed beyond the gear ratio in the table, attach a decimal gearhead (gear ratio:10) between the gearhead and motor. In that case, the permissible torque is 20N·m.

■ 容许力矩单位 Allowance Torque Unit：上段 Upside (N.m) /下段 Belowside (kgf.cm)

类型 Type 电动机/减速机 Motor/Gearhead	减速比 Gear Ratio		3	3.6	5	6	7.5	9	10	12.5	15	18	20	25	30	36	40	50	60	75	90	100	120	150	180	200	
	转速 Speed r/min	50Hz	500	417	300	250	200	166	150	120	100	83	75	60	50	41	37	30	25	20	16	15	12.5	10	8.3	7.5	
5IK120RGU-AF 5IK120RGU-EF 5IK120RGU-CF 5IK120RGU-HF	5GU□KB 5GU□K	50Hz	2.30	2.70	3.80	4.50	5.60	6.80	7.01	8.50	10.2	12.2	12.5	15.3	18.4	20.0	20.0	20.0	20.0	20.0	20.0	20.0	20.0	20.0	20.0	20.0	20.0
		60Hz	23.4	27.5	38.7	45.9	57.1	69.3	71.5	86.7	104	124	128	156	187	200	200	200	200	200	200	200	200	200	200	200	200
	50Hz	1.80	2.20	3.00	3.60	4.60	5.50	5.73	6.80	8.20	9.80	10.1	12.4	14.9	17.8	19.5	20.0	20.0	20.0	20.0	20.0	20.0	20.0	20.0	20.0	20.0	20.0
		60Hz	18.3	22.4	30.6	36.7	46.9	56.1	58.5	69.5	83.6	100	103	126	152	181	199	200	200	200	200	200	200	200	200	200	200

■ 容许悬挂负载·容许轴向负载 To Allow The Hoisting Of The Load Allow Axial Load

电动机 (圆轴型) →215页 Motor (Round shaft) →P215
 减速机→215页 Gearhead→P215

■ 减速机的容许负载惯性惯量 J Permissible Load Inertia J For Gearhead

→215页→P215

■ 外形图 (单位 mm) Dimensions (Unit mm)

减速机附有安装用螺丝 Mounting screws are included with gearhead.

● 导线型 Lead Wiring Type

重量 Weight：电动机 Motor：3.5kg 减速器 Gearhead：1.5kg

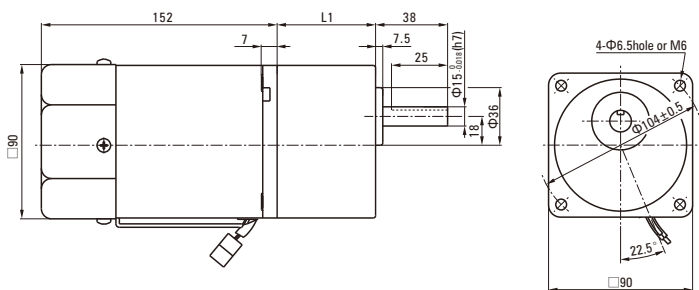

电动机型号 Motor Model	减速器型号 Gearhead Model	减速比 Gear Ratio	L1
5IK90RGU-AF 5IK90RGU-EF 5IK90RGU-CF 5IK90RGU-HF	5GU□KB	3~200	65.5

- 减速器型号的□中为减速比的数值
Enter the gear ratio in the box (□) within the model name

● 凸缘安装型减速器 Flange Mounting Reducer

可安装在GU齿轮轴型上
Can be mounted on GU type gear shaft
5GU□K
重量Weight:1.5kg

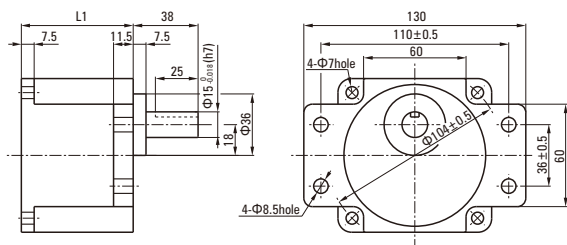

● 键·键槽 (减速器附件)

Key · Keyway (Accessory of Gearhead)

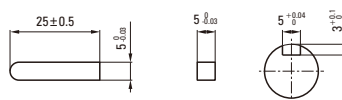

● 圆轴型的转轴部分 Shaft Section Of Round Shaft Type

除重量及轴部外电动机外形与齿轮轴型相同。
Excluding weight and the shaft section motor shape are the same as those of the pinion shaft type.

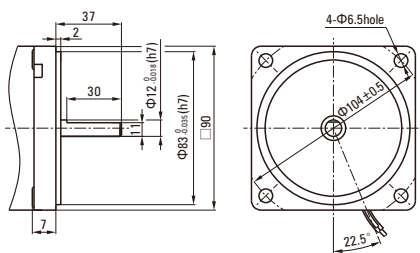

● 中间减速器 Decimal Gearhead

可安装在GU齿轮轴型上 Can be connected to GU pinion shaft type
电动机外形与齿轮轴型相同
5GU10XK
重量 Weight : 0.65kg

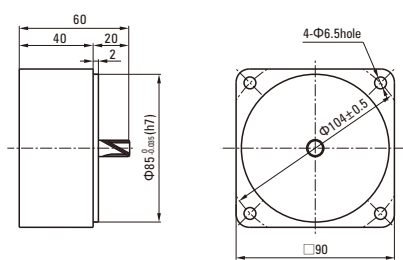

■ 连接图 Wiring Diagram

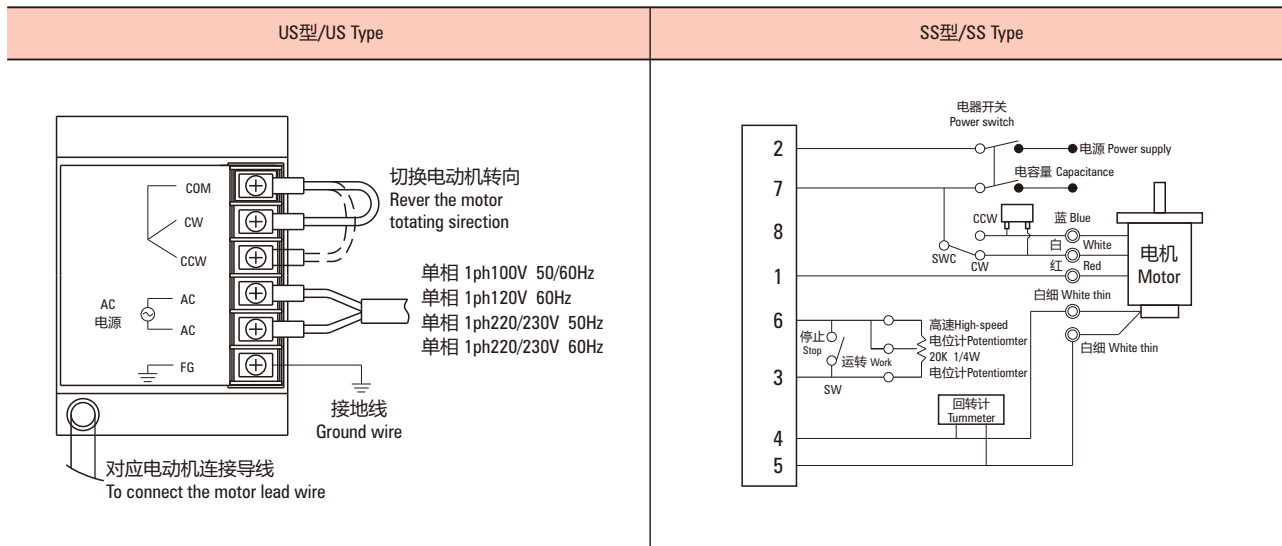

调速电动机 SPEED ADJUSTABLE MOTOR

■ 120W □ 104mm

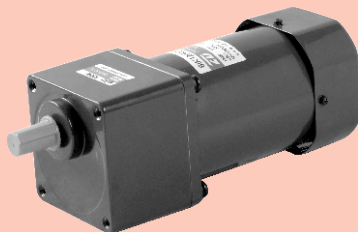

规格 Specs 连续额定 Cont. Rated

型号Model · 类型 Type 导线型 Lead Wire Type		最大 输出功率 Output power W	电压 Voltage V	频率 Frequency Hz	调速范围 Speed Control Range r/min	容许转矩 Allowance Torque		启动转矩 Starting Torque mN.m	电流 Current A	电容器容量 Capacitor μF
齿轮轴型 Pinion Shaft	圆轴型 Round Shaft					1200r/min mN.m	90r/min mN.m			
6IK120RGU-AF	6IK120RA-AF	120	1ph 100	50	90~1350	750	360	530	2.10	30.0
				60	90~1650				2.50	
6IK120RGU-EF	6IK120RA-EF	120	1ph 110	60	90~1650	750	360	520	1.70	20.0
			1ph 120						1.80	
6IK120RGU-CF	6IK120RA-CF	120	1ph 220	50	90~1350	750	330	530	0.95	8.0
			1ph 230						0.95	
6IK120RGU-HF	6IK120RA-HF	120	1ph 220	60	90~1650	750	360	530	0.95	8.0
			1ph 230						1.00	

●各种安全规格以电动机铭牌上的型号取得认证。

When the motor is approved under various safety standards, the model name on the nameplate is the approved model name.

●注：“-A”型号中电压为110V时，配置电容器容量以实际铭牌为准。

Note:“-A” it means the voltage 110V, the assembly capacitor vaule it is according the labe.

种类 Type

● 电动机 Motor

机型 Type	型号Model	
	齿轮轴型 Pinion Shaft	圆轴型 Round Shaft
导线型 Lead Wire Type	6IK120RGU-AF	6IK120RA-AF
	6IK120RGU-EF	6IK120RA-EF
	6IK120RGU-CF	6IK120RA-CF
	6IK120RGU-HF	6IK120RA-HF

● 平行轴减速器（另售）Parallel Shaft Gearhead (Sold Separately)

减速器种类 Gearhead Type	减速器型号 Gearhead Model	减速比 Gear Ratio
长寿命●低噪音 Long Life ● Low Noise	6GU□K	3、3.6、5、6、7.5、9、10、 12.5、15、18、20、25、30、 36、40、50、60、75、90、 100、120、150、180、200

●减速器型号的□中为减速比的数值

Enter the gear ratio in the box (□) within the model name

■ 装有减速器时的容许转矩 Gear Motor-Torque Table

- 减速器另售·中间减速器另售。电动机型号的□中为表示带端子箱型的记号(T)。
Gearhead and mid-gearbox can be sold separately. Enter the code that represents the terminal box type (T) in the box (□) within the model name.
- 减速品型号的□中为减速比的数值。
Enter the gear ratio in the box (□) within the model name.
- □色表示与电动机同一方向运转，其他则为相反方向。
The colored background □ indicates the same rotating direction of the motor while the rotating direction of others are opposite.
- 转速是以电动机的同步转速（50Hz：1500r/min、60Hz：1800r/min）为基准除以减速比而算出来的数值。实际转速将随负载大小变化所示数值减少2%~20%左右。
The speed is calculated by dividing the motor's synchronous speed (50Hz：1500r/min、60Hz：1800r/min) by the gear ratio. The actual speed is 2%~20% less than the displayed value, depending on the size of the load.

■ 容许力矩单位 Allowance Torque Unit：上段 Upside (N.m) /下段 Belowside (kgf.cm)

类型 Type 电动机/减速机 Motor/Gearhead	减速比 Gear Ratio		3	3.6	5	6	7.5	9	10	12.5	15	18	20	25	30	36	40	50	60	75	90	100	120	150	180	200	
	转速 Speed r/min	50Hz	60Hz	50Hz	60Hz	50Hz	60Hz	50Hz	60Hz	50Hz	60Hz	50Hz	60Hz	50Hz	60Hz	50Hz	60Hz	50Hz	60Hz	50Hz	60Hz	50Hz	60Hz	50Hz	60Hz	50Hz	60Hz
6IK120RGU-AF□ 6IK120RGU-EF□ 6IK120RGU-CF□ 6IK120RGU-HF□	6GU□K	50Hz	2.30	2.70	3.80	4.50	5.60	6.80	6.68	8.50	10.2	12.2	12.0	15.3	18.4	22.1	24.0	30.7	36.8	40.0	40.0	40.0	40.0	40.0	40.0	40.0	40.0
		60Hz	23.4	27.5	38.7	45.9	57.1	69.3	68.2	86.7	104	124	123	156	187	225	245	313	375	400	400	400	400	400	400	400	400
		50Hz	1.80	2.20	3.00	3.60	4.60	5.50	5.40	6.80	8.20	9.80	9.70	12.4	14.9	17.8	19.4	24.8	29.7	37.1	40.0	40.0	40.0	40.0	40.0	40.0	40.0
		60Hz	18.3	22.4	30.6	36.7	46.9	56.1	55.0	69.3	83.6	100	99.0	126	152	181	198	253	303	378	400	400	400	400	400	400	400

■ 容许悬挂负载·容许轴向负载 To Allow The Hoisting Of The Load Allow Axial Load

电动机 (圆轴型) →P215页
减速机 →P215页

Motor (Round shaft) →P215
Gearhead →P215

■ 减速机的容许负载惯性惯量 J Permissible Load Inertia J For Gearhead

→P215页 →P215

■ 外形图 (单位 mm) Dimensions (Unit mm)

减速机附有安装用螺丝 Mounting screws are included with gearhead.

● 导线型 Lead Wiring Type

重量 Weight：电动机 Motor：4.9kg

减速机 Gearhead：2.1kg

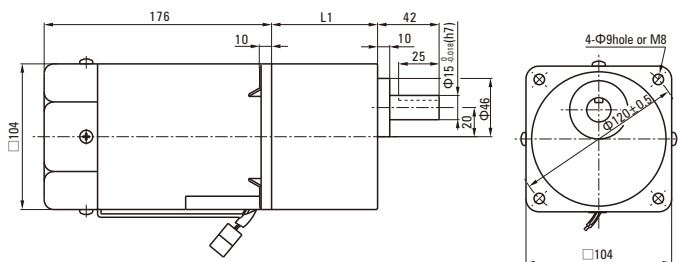

电动机型号 Motor Model	减速机型号 Gearhead Model	减速比 Gear Ratio	L1
6IK120RGU-AF 6IK120RGU-EF 6IK120RGU-CF 6IK120RGU-HF	6GU□K	3~200	72

- 减速机型号的□中为减速比的数值
Enter the gear ratio in the box (□) within the model name

● 圆轴型的转轴部分 Shaft Section Of Round Shaft Type

除重量及轴部外电动机外形与齿轮轴型相同。
Excluding weight and the shaft section motor shape are the same as those of the pinion shaft type.

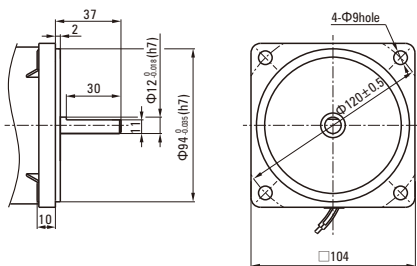

● 键·键槽 (减速器附件)

Key · Keyway (Accessory of Gearhead)

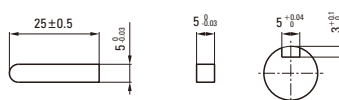

■ 连接图 Wiring Diagram

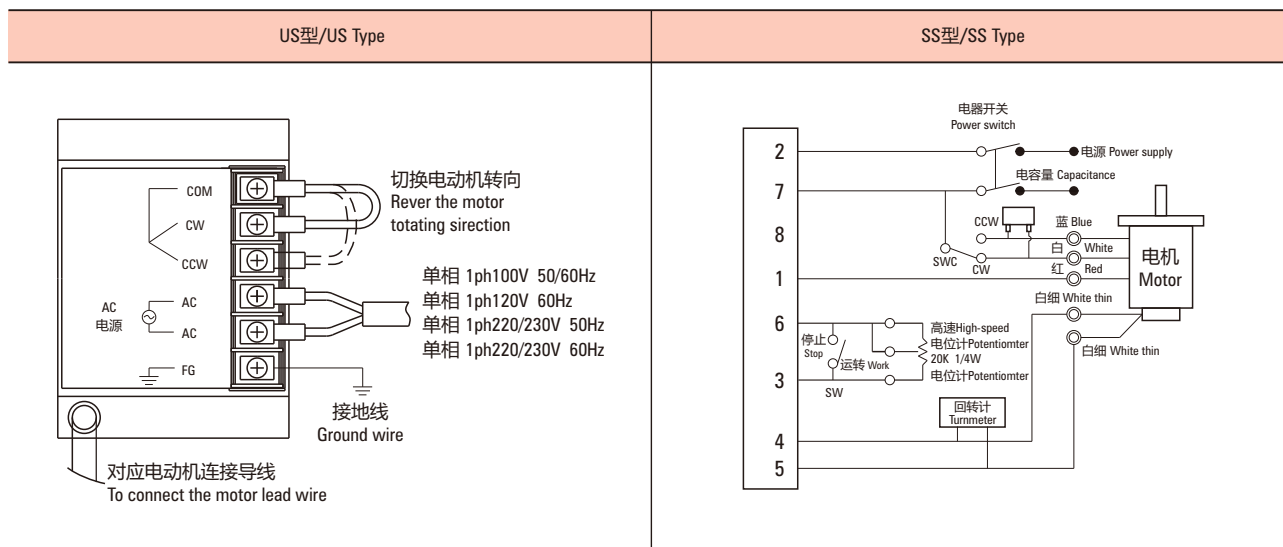

说明
Explain

感应电动机
Induction Motor

可逆电动机
Reversible Motors

刹车电动机
Brake Motors

调速电动机
Speed Control Motors

转矩电动机
Torque Motors

调速电动机 SPEED ADJUSTABLE MOTOR

■ 140W □ 104mm

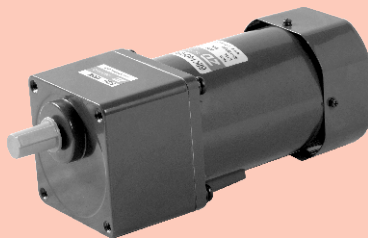

规格 Specs 连续额定 Cont. Rated

型号Model · 类型 Type 导线型 Lead Wire Type		最大 输出功率 Output power W	电压 Voltage V	频率 Frequency Hz	调速范围 Speed Control Range r/min	容许转矩 Allowance Torque		启动转矩 Starting Torque mN.m	电流 Current A	电容器容量 Capacitor μF
齿轮轴型 Pinion Shaft	圆轴型 Round Shaft					1200r/min mN.m	90r/min mN.m			
6IK140RGU-AF	6IK140RA-AF	140	1ph 100	50	90~1350	830	420	620	2.70	35.0
				60	90~1650				3.00	
6IK140RGU-EF	6IK140RA-EF	140	1ph 110	60	90~1650	830	450	620	1.80	25.0
			1ph 120						1.95	
6IK140RGU-CF	6IK140RA-CF	140	1ph 220	50	90~1350	830	420	620	1.05	10.0
			1ph 230						1.15	
6IK140RGU-HF	6IK140RA-HF	140	1ph 220	60	90~1650	830	450	620	1.05	10.0
			1ph 230						1.15	

●各种安全规格以电动机铭牌上的型号取得认证。

When the motor is approved under various safety standards, the model name on the nameplate is the approved model name.

●注：“-A”型号中电压为110V时，配置电容器容量以实际铭牌为准。

Note: "-A" it means the voltage 110V, the assembly capacitor value it is according to the label.

种类 Type

● 电动机 Motor

机型 Type	型号Model	
	齿轮轴型 Pinion Shaft	圆轴型 Round Shaft
导线型 Lead Wire Type	6IK140RGU-AF	6IK140RA-AF
	6IK140RGU-EF	6IK140RA-EF
	6IK140RGU-CF	6IK140RA-CF
	6IK140RGU-HF	6IK140RA-HF

● 平行轴减速器（另售） Parallel Shaft Gearhead (Sold Separately)

减速器种类 Gearhead Type	减速器型号 Gearhead Model	减速比 Gear Ratio
长寿命●低噪音 Long Life ● Low Noise	6GU□K	3、3.6、5、6、7.5、9、10、 12.5、15、18、20、25、30、 36、40、50、60、75、90、 100、120、150、180、200

●减速器型号的□中为减速比的数值

Enter the gear ratio in the box (□) within the model name

■ 装有减速器时的容许转矩 Gear Motor-Torque Table

- 减速器另售·中间减速器另售。电动机型号的□中为表示带端子箱型的记号(T)。
Gearhead and mid-gearbox can be sold separately. Enter the code that represents the terminal box type (T) in the box (□) within the model name.
- 减速品型号的□中为减速比的数值。
Enter the gear ratio in the box (□) within the model name.
- □色表示与电动机同一方向运转，其他则为相反方向。
The colored background □ indicates the same rotating direction of the motor while the rotating direction of others are opposite.
- 转速是以电动机的同步转速（50Hz：1500r/min、60Hz：1800r/min）为基准除以减速比而算出来的数值。实际转速将随负载大小变化所示数值减少2%~20%左右。
The speed is calculated by dividing the motor's synchronous speed (50Hz：1500r/min、60Hz：1800r/min) by the gear ratio. The actual speed is 2%~20% less than the displayed value, depending on the size of the load.

■ 容许力矩单位 Allowance Torque Unit：上段 Upside (N.m) /下段 Belowside (kgf.cm)

类型 Type 电动机/减速器 Motor/Gearhead	减速比 Gear Ratio		3	3.6	5	6	7.5	9	10	12.5	15	18	20	25	30	36	40	50	60	75	90	100	120	150	180	200	
	转速 Speed r/min	50Hz	500	417	300	250	200	166	150	120	100	83	75	60	50	41	37	30	25	20	16	15	12.5	10	8.3	7.5	
6IK140RGU-AF 6IK140RGU-EF 6IK140RGU-CF 6IK140RGU-HF	6GU□K	60Hz	600	500	360	300	240	200	180	144	120	100	90	72	60	50	45	36	30	24	20	18	15	12	10	9	
		50Hz	2.60	3.10	4.40	5.20	6.60	7.90	7.80	9.90	11.8	14.2	14.0	17.8	21.4	25.7	28.0	35.6	40.0	40.0	40.0	40.0	40.0	40.0	40.0	40.0	40.0
	6GU□K	60Hz	26.5	31.6	44.8	53.0	80.6	80.6	79.6	101	120	144	143	181	218	262	286	263	400	400	400	400	400	400	400	400	400
		50Hz	2.10	2.50	3.50	4.20	5.30	6.30	6.30	7.90	9.50	11.4	11.3	14.4	17.2	20.7	22.6	28.7	34.5	40.0	40.0	40.0	40.0	40.0	40.0	40.0	40.0

■ 容许悬挂负载 · 容许轴向负载 To Allow The Hoisting Of The Load Allow Axial Load

电动机 (圆轴型) →P215页 Motor (Round shaft) →P215
 减速机 →P215页 Gearhead →P215

■ 减速机的容许负载惯性惯量 J Permissible Load Inertia J For Gearhead

→P215页 →P215

■ 外形图 (单位 mm) Dimensions (Unit mm)

减速器附有安装用螺丝 Mounting screws are included with gearhead.

● 导线型 Lead Wiring Type

重量 Weight：电动机 Motor：5.1kg 减速器 Gearhead：2.1kg

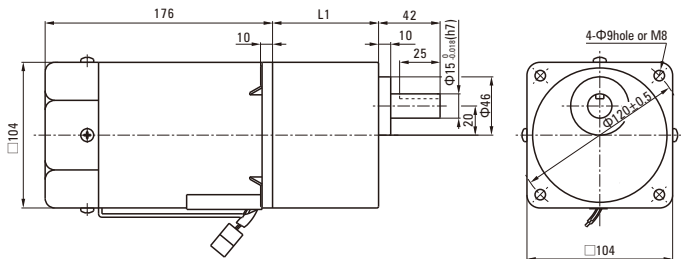

电动机型号 Motor Model	减速器型号 Gearhead Model	减速比 Gear Ratio	L1
6IK140RGU-AF 6IK140RGU-EF 6IK140RGU-CF 6IK140RGU-HF	6GU□K	3~200	72

- 减速器型号的□中为减速比的数值
Enter the gear ratio in the box (□) within the model name

● 圆轴型的转轴部分 Shaft Section Of Round Shaft Type

除重量及轴部外电动机外形与齿轮轴型相同。
Excluding weight and the shaft section motor shape are the same as those of the pinion shaft type.

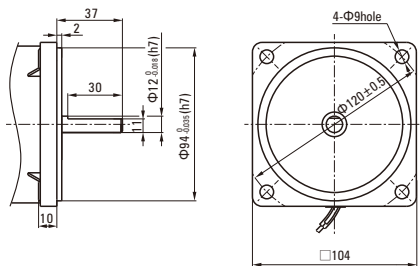

● 键·键槽 (减速器附件)

Key · Keyway (Accessory of Gearhead)

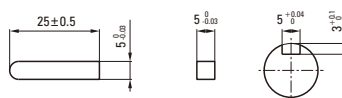

■ 连接图 Wiring Diagram

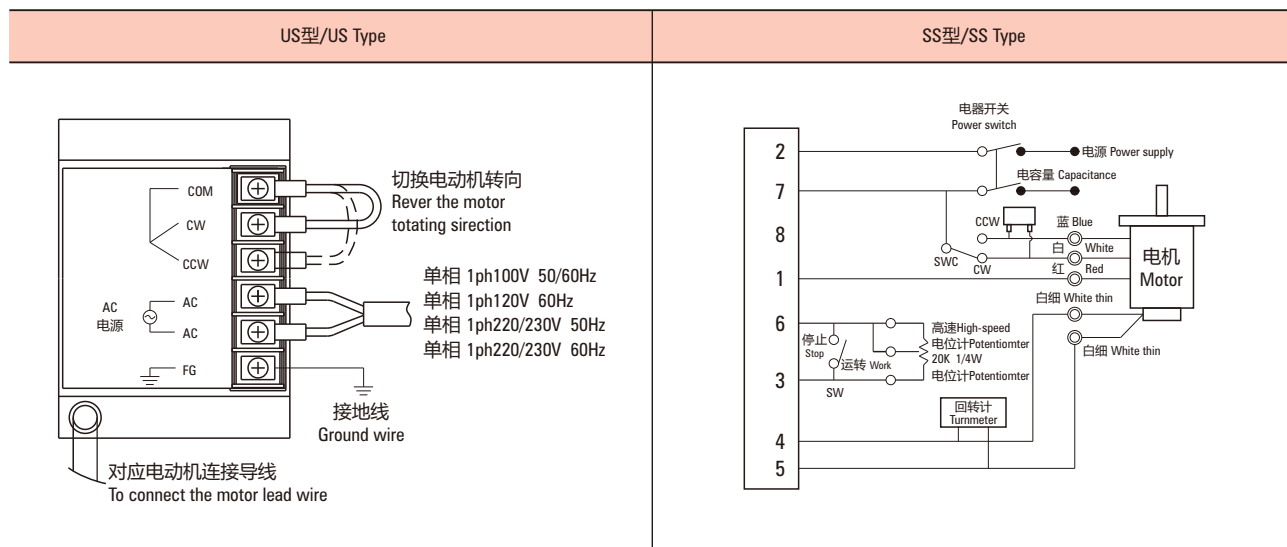

调速电动机 SPEED ADJUSTABLE MOTOR

■ 200W □ 104mm

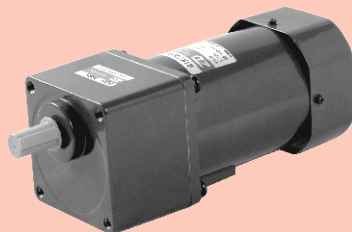

规格 Specs 连续额定 Cont. Rated

型号Model · 类型 Type 导线型 Lead Wire Type		最大 输出功率 Output power W	电压 Voltage V	频率 Frequency Hz	调速范围 Speed Control Range r/min	容许转矩 Allowance Torque		启动转矩 Starting Torque mN.m	电流 Current A	电容器容量 Capacitor μF
齿轮轴型 Pinion Shaft	圆轴型 Round Shaft					1200r/min mN.m	90r/min mN.m			
6IK200RGU-CF	6IK200RA-CF	200	1ph 220	50	90~1350	920	500	1000	1.4	10.0
			1ph 230							
6IK200RGU-HF	6IK200RA-HF	200	1ph 220	60	90~1650	920	500	1000	1.4	10.0
			1ph 230							

●各种安全规格以电动机铭牌上的型号取得认证。

When the motor is approved under various safety standards, the model name on the nameplate is the approved model name.

●注：“-A”型号中电压为110V时，配置电容器容量以实际铭牌为准。

Note: "-A" it means the voltage 110V, the assembly capacitor vaule it is according the labe.

种类 Type

● 电动机 Motor

机型 Type	型号Model	
	齿轮轴型 Pinion Shaft	圆轴型 Round Shaft
导线型 Lead Wire Type	6IK200RGU-CF	6IK200RA-CF
	6IK200RGU-HF	6IK200RA-HF

● 平行轴减速器 (另售) Parallel Shaft Gearhead (Sold Separately)

减速器种类 Gearhead Type	减速器型号 Gearhead Model	减速比 Gear Ratio
长寿命●低噪音 Long Life ● Low Noise	6GU□K	3、3.6、5、6、7.5、9、10、 12.5、15、18、20、25、30、 36、40、50、60、75、90、 100、120、150、180、200

●减速器型号的□中为减速比的数值

Enter the gear ratio in the box (□) within the model name

■ 装有减速器时的容许转矩 Gear Motor-Torque Table

- 减速器另售·中间减速器另售。
Gearhead are sold separately. Decimal gearheads are not available.
- 减速品型号的□中为减速比的数值。
Enter the gear ratio in the box (□) within the model name.
- □色表示与电动机同一方向运转，其他则为相反方向。
The colored background □ indicates the same rotating direction of the motor while the rotating direction of others are opposite.
- 转速是以电动机的同步转速（50Hz：1500r/min、60Hz：1800r/min）为基准除以减速比而算出来的数值。实际转速将随负载大小变化所示数值减少2%~20%左右。
The speed is calculated by dividing the motor's synchronous speed (50Hz：1500r/min、60Hz：1800r/min) by the gear ratio. The actual speed is 2%~20% less than the displayed value, depending on the size of the load.

■ 容许力矩单位 Allowance Torque Unit：上段 Upside (N.m) /下段 Belowside (kgf.cm)

类型 Type 电动机/减速机 Motor/Gearhead	减速比 Gear Ratio		容许力矩																							
			3	3.6	5	6	7.5	9	10	12.5	15	18	20	25	30	36	40	50	60	75	90	100	120	150	180	200
6IK200RGU-CF 6IK200RGU-HF	6GU□K	50Hz	3.71	4.46	6.19	7.43	9.28	11.1	11.9	13.9	16.7	20.1	20.8	25.2	30.3	36.3	40.0	40.0	40.0	40.0	40.0	40.0	40.0	40.0	40.0	40.0
			37.9	45.5	63.1	75.8	94.7	114	121	142	171	205	212	257	309	370	400	400	400	400	400	400	400	400	400	400
	60Hz	2.99	3.59	4.99	5.99	7.49	8.98	9.70	11.2	13.5	16.2	17.2	20.3	24.4	29.3	40.0	40.0	40.0	40.0	40.0	40.0	40.0	40.0	40.0	40.0	40.0
		30.6	36.7	50.9	61.1	76.4	91.7	98.9	115	138	165	175	207	249	299	400	400	400	400	400	400	400	400	400	400	400

■ 容许悬挂负载·容许轴向负载 To Allow The Hoisting Of The Load Allow Axial Load

电动机（圆轴型）→P215页 Motor (Round shaft) →P215
减速机→P215页 Gearhead→P215

■ 减速机的容许负载惯性惯量 J Permissible Load Inertia J For Gearhead

→P215页→P215

■ 外形图（单位 mm）Dimensions (Unit mm)

减速机附有安装用螺丝 Mounting screws are included with gearhead.

● 导线型 Lead Wiring Type

重量 Weight：电动机 Motor：5.1kg 减速机 Gearhead：2.1kg

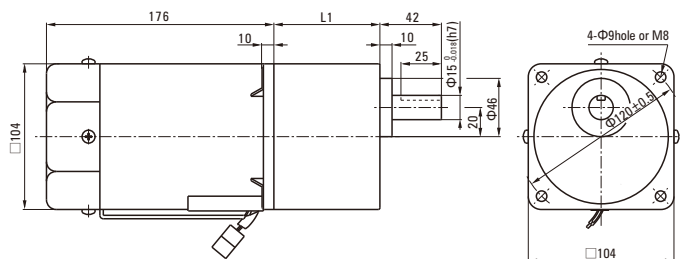

电动机型号 Motor Model	减速机型号 Gearhead Model	减速比 Gear Ratio	L1
6IK200RGU-CF 6IK200RGU-HF	6GU□K	3~200	72

- 减速机型号的□中为减速比的数值
Enter the gear ratio in the box (□) within the model name

● 圆轴型的转轴部分 Shaft Section Of Round Shaft Type

除重量及轴部外电动机外形与齿轮轴型相同。
Excluding weight and the shaft section motor shape are the same as those of the pinion shaft type.

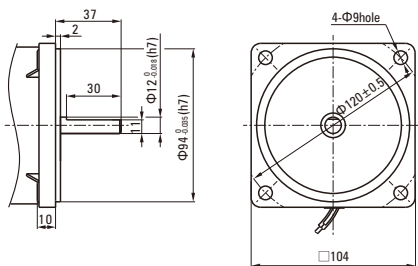

● 键·键槽 (减速器附件)

Key · Keyway (Accessory of Gearhead)

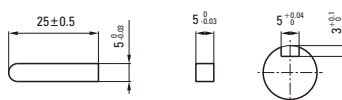

■ 连接图 Wiring Diagram

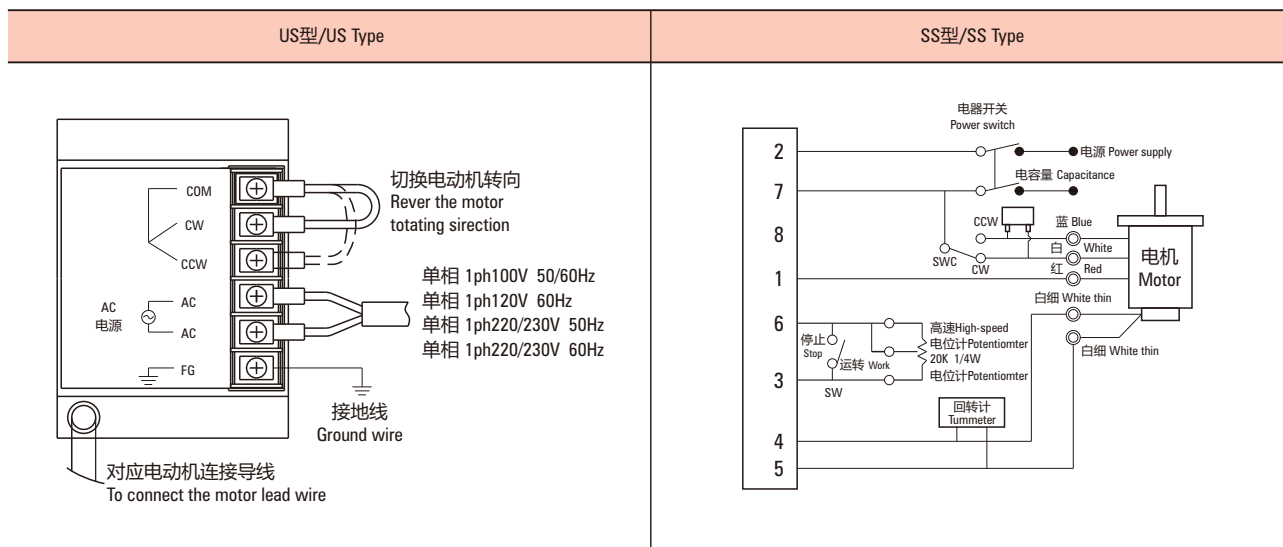

说明
Explain

感应电动机
Induction Motor

可逆电动机
Reversible Motors

刹车电动机
Brake Motors

调速电动机
Speed Control Motors

转矩电动机
Torque Motors

调速电动机 SPEED ADJUSTABLE MOTOR

控制器型号说明 Description Of Governor Model

U

调速器种类
Speed controller type
U: 组合型
U: Combination

S: 分离型
S: Separation

S

调速器种类
Speed controller type
S: 速度控制器
S: Speed governor

11

电压
Voltage
11: 单相110V50Hz
11: Single phase 110V50Hz

22: 单相220V50Hz
22: Single phase 220V50Hz

33: 数字显示器
33: Digital display

A

电容安装方式
Capacitor mounting type
A: 内置式电容器
A: Built-in capacitor

B: 外置式电容器
B: External capacitor

组合型 Combination SS11、SS22 正、反转变速 Clockwise And Anti-Clockwise Speed Change

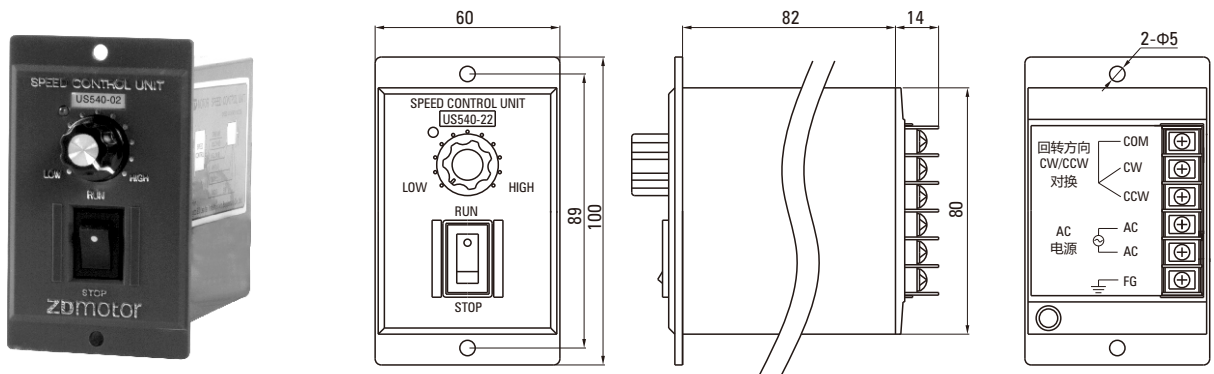

分离器 Separation SS11、SS22 正、反转变速 Clockwise And Anti-Clockwise Speed Change

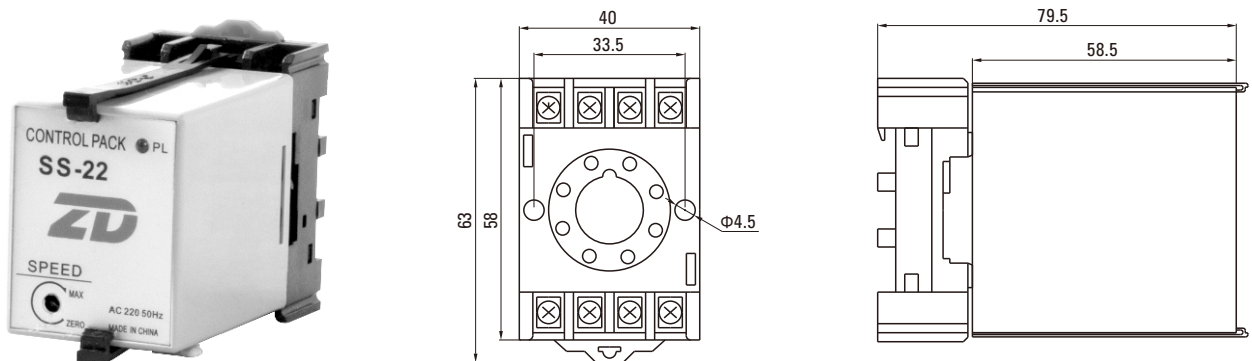

调速器特性表 List Of Speed Governor Characteristics

参数Parameter 型号Model	电压(V) Voltage(V)	频率(Hz) Voltage(Hz)	最大电流(A) Peak Current(A)	电机功率(W) Motor Power(W)	速度范围(r/min) Speed Range(r/min)	速度变速器 Speed Changer	速度应答器 Speed Responder	速度安定性 Speed Stability	工作环境温度 Working Ambient Temperature
US11	110V±10%	50/60	5	6~140	90/1350	3%	(0.5)	优 Excellent	-10°C~+50°C
US22	220V±10%			6~200	90/1650				
US11	110V±10%	50/60	5	6~140	90/1350	3%	(0.5)	优 Excellent	-10°C~+50°C
US22	220V±10%			6~200	90/1650				
US33	110V±10%	50/60	5	6~140	90/1350	3%	(0.5)	优 Excellent	-10°C~+50°C
	220V±10%			6~200	90/1650				

调速电动机 SPEED ADJUSTABLE MOTOR

调速器型号命名方法 Governor Type Designation Method

ZD

中大电机简写
ZD motor shorthand

F

机型 Model
F: 面板式 Panel type
K: 内置式 Built in
M: 面板式刹车 Panel brake

200

适用调速电机功率
代号: 6W-200W
Adjustable speed motor power
Code: 6W-200W

E

电压 Voltage
E: 单相220V Single-phase 220V
A: 单相110V Single-phase 110V



分支型号
Branch model

调速器性能参数 Governor Performance Parameter

型号 Model	ZDF□□E	ZDF□□A	ZDK200E	ZDK200A
安装方式 Installation method	面板式 Panel type		内置式 Built in	
电源电压 Supply voltage	单相 Single-phase 220V	单相 Single-phase 110V	单相 Single-phase 220V	单相 Single-phase 110V
电源频率 Power frequency	50Hz/60Hz			
适用电机类型 Applicable motor type	调速电动机 Speed regulating motor			
运行电容 Run capacitor	内置 (内置于调速器内) Built in (Built-in governor)		外置 (放置于调速电机包装内, 需要用户连接) External (Placed in the motor package, the user needs to connect)	
运动控制功能 Motion control function	面板或外接开关运转控制、调速、缓慢加速、缓慢减速 Panel or external switch operation control, speed control, slow acceleration, slow deceleration		外接开关运转控制、调速、缓慢加速、缓慢减速、快速停止、4段速 External switch operation control, speed control, slow acceleration, slow deceleration, fast stop, 4 speed	
速度调节 Speed regulation	面板“▲”“▼”键, 旋钮 “▲” and “▼” panel button, knob		面板“▲”“▼”键, 旋钮, 0-10V模拟量 “▲” and “▼” panel button, knob, 0-10V analog quantity	
速度范围 Speed range	90-3000r/min (用户可根据电机参数、电源频率、使用需要设定) 90-3000r/min (The user can be set according to the motor parameters, power frequency, use need)			
使用环境 Use environment	环境温度: -10°C~+45°C (无结冰) Ambient temperature: ~+45°C -10°C (No icing) 环境湿度: 85%RH (无结霜) Humidity: 85%RH (No frost)			

调速器性能参数 Governor Performance Parameter

类别 Category 电源电压 Supply Voltage 电机功率 Motor Power	ZDF系列面板式调速器 ZDF Series Plate Type Speed Regulator		ZDK系列内置式调速器 ZDK Series Built-in Governor	
	220V	110V	220V	110V
6W	ZDF06E	ZDF06A	ZDK200E	ZDK200A
15W	ZDF15E	ZDF15A		
25W	ZDF25E	ZDF25A		
40W	ZDF40E	ZDF40A		
60W	ZDF60E	ZDF60A		
90W	ZDF90E	ZDF90A		
120W	ZDF120E	ZDF120A		
140W	ZDF140E	ZDF140A		
200W	ZDF200E	ZDF200A		

说明
Explain

感应电动机
Induction Motor

可逆电动机
Reversible Motors

刹车电动机
Brake Motors

调速电动机
Speed Control Motors

转矩电动机
Torque Motors

面板式调速器 PANEL TYPE SPEED REGULATOR



■ 面板式特点 Panel Features

- 采用MCU数字控制技术，功能丰富，性能优异。
 - 采用数显菜单式选项，修改设定方便快捷。
 - 根据用户显示需要显示倍率，自动换算显示目标值。
 - 可实现缓慢加速，缓慢减速。
 - 可面板操作、外接开关控制。
 - 面板旋钮自动匹配最高转速，调速控制方便，安全。
 - 内置运行电容。
 - 堵转保护功能，防止电机、调速器因堵转烧坏。
- Adopt MCU digital control technology, feature rich, excellent performance.
 - The display menu options, modify the settings conveniently.
 - According to the user needs to display display magnification, automatic conversion display target value.
 - It can realize the slow acceleration, deceleration.
 - Operation, external switch control panel.
 - Automatic matching of maximum speed-speed control panel knob, convenient and safe.
 - The built-in running capacitor.
 - The blocking protection function, prevent blockage due to burn motor, speed governor.

■ 面板式调速器接线图 Panel Type Governor Connection Diagram

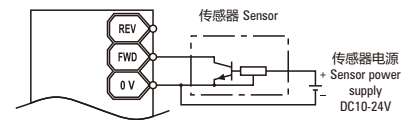
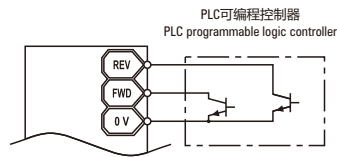
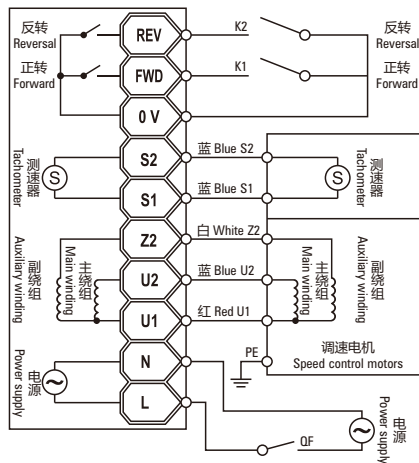

■ 面板式调速器安装规格图 Panel Governor Installation Specifications

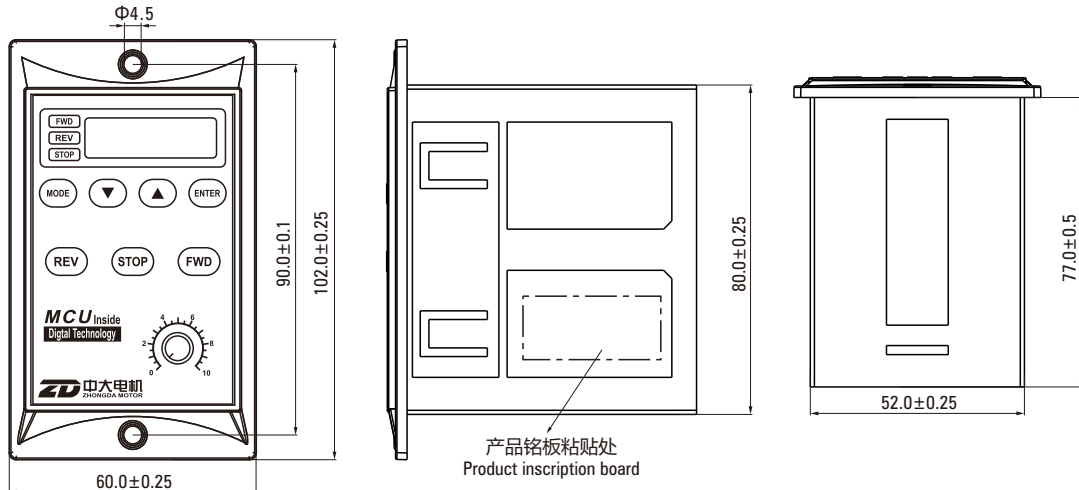

■ 面板式调速器菜单 Panel Governor Menu

● 菜单修改：Menu modification:

注意：为保证安全，F-05、F-29参数修改必须在电机停止状态下进行，否则无法，屏幕显示“Err”。

Note: in order to ensure safety, F-05, F-29 parameters must be modified in the motor to stop the state, otherwise unable to, the screen display "Err".

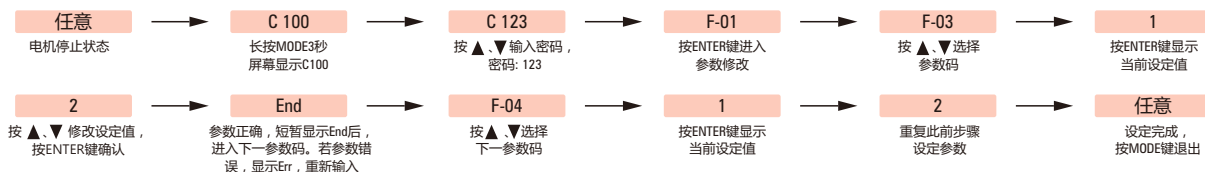

■ 面板式调速菜单清单： Panel Speed Control Menu List:

参数码	参数功能	设定范围	功能说明	出厂设定
F-01	显示内容	1. 电机转速设定值 2. 倍率转速设定值	倍率转速设定值=电机转速设定值×倍率	1
F-02	倍率设定	1.0-999.9	根据显示直观性需要设定，显示目标值。	1.0
F-03	运转控制方式	1. 操作按面板按钮控制，无记忆 2. 外接开关控制，面板“STOP”键无效 3. 外接开关控制，面板“STOP”键有效 4. 操作面板按钮控制有记忆	选择“1”由面板按钮控制电机，关闭调速器电源后再次打开电源，调整器不记忆关电前的运转状态，重新上电，电机为停止状态。 选择“4”调速器记忆关电前的状态，重新上电后电机为上次关电前的状态。 例：关电前电机正转，再次上电电机立即正转。选择此功能，请注意安全！ 选择外接开关控制时，由FWD、REV外接开关K1，K2控制电机	1
F-04	旋转方式	1. 允许正反转 2. 允许正转，禁止反转 3. 允许反转，禁止正转	限制电机旋转方向，防止设备故障或者事故。	1
F-05	旋转方向	1. 不取反 2. 取反	无需改变电机旋转方向，方便快捷改变电机转向使之与习惯或要求一致	1
F-06	调速方式	1. 面板按钮“▲”“▼” 2. 面板旋钮	按“▲”“▼”按钮在最低至最高转速范围内调整电机转速面板旋钮自动匹配0-最高转速。	1
F-07	最高转速	500-1700 500-3000	限制电机最高转速，可防止超速，发生损坏或事故。	800 1400
F-08	最低转速	120-1000 90-1000	限制电机最低转速，可防止电机由于运行低速导致不稳定，过热，过载。	120 90
F-09	正转起 加速时间	0-10秒（自动匹配） 0.1-10秒（手动匹配）	设置时间长，电机起平缓，起时间长。 设置时间短，电机起快猛，起时间短。	1.0
F-10	正转停止方式	1. 自由减速停止 2. 缓慢减速停止	当选择自由减速停止时，若电机停止较快，可选择缓慢减速停止，改变F-11设定值，可改变缓慢减速停止快慢。	1
F-11	正转停止时 缓慢减速时间	0-10秒（自动匹配） 0.1-10秒（手动匹配）	F-10选择2时菜单有效	0 1.0
F-12	反转起 加速时间	0-10秒（自动匹配） 0.1-10秒（手动匹配）	设置时间长，电机起平缓，起时间长。 设置时间短，电机起快猛，起时间短。	0 1.0
F-13	反转停止方式	1. 自由减速停止 2. 缓慢减速停止	当选择自由减速停止时，若电机停止较快，可选择缓慢减速停止，改变F-14设定值，可改变缓慢减速停止快慢。	1
F-14	反转停止时 缓慢减速时间	0-10秒（自动匹配） 0.1-10秒（手动匹配）	F-13选择2时菜单有效	0 1.0
F-29	恢复出厂设定	1. 不恢复 2. 恢复出厂设定		1
F-30	程序版本	代码+版本		01.**

故障报警Er-1：

1. 过载堵转
2. 调速器与电机的连接异常

故障处理：

1. 检查、排除故障
2. 重新上电解除故障

内置式调速器 BUILT IN GOVERNOR

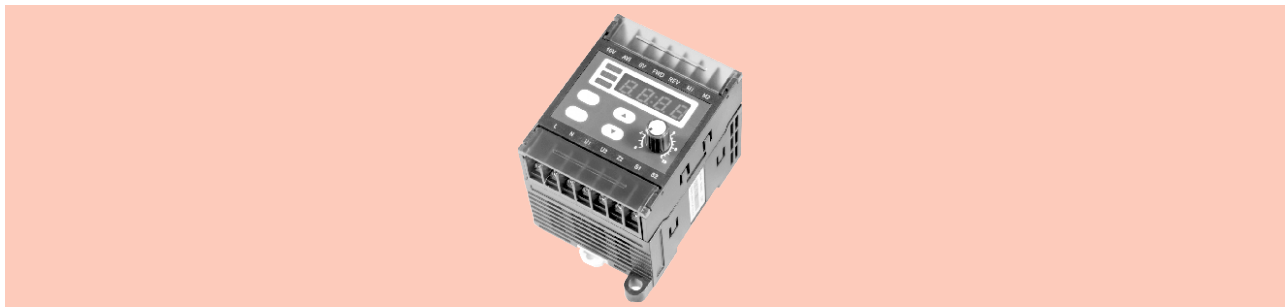

■ 内置式特点 Built In Features

- 采用MCU数字控制技术，功能丰富，性能优异。
- 采用数显菜单式选项，修改设定方便快捷。
- 可根据用户显示需要设定显示倍率，自动换算显示目标值。
- 可实现缓慢加速、缓慢减速、快速停止、4段速等复杂运动控制。
- 可外接开关控制、0-10V模拟量控制。
- 模拟量控制可自动匹配最高转速，调节控制方便、安全。
- 堵转保护功能，防止电机、调速器因堵转烧坏。
(此功能可保护堵转过载、但无法保护非堵转过载)
- Adopt MCU digital control technology, feature rich, excellent performance.
- The display menu options, modify the settings conveniently.
- Can be based on user needs to set the display magnification display, automatic conversion display target value.
- It can realize the slow acceleration, deceleration, speed, quick stop 4 complex motion control.
- The external control switch, 0-10V analog control.
- The analog quantity control can automatically match the highest speed, convenient control and safety regulation.
- The blocking protection function, prevent blockage due to burn motor, speed governor.
(this feature can be protected against overload, but can not protect the non blocking overload)

■ 内置式调速器接线图 Built-in Governor Connection Diagram

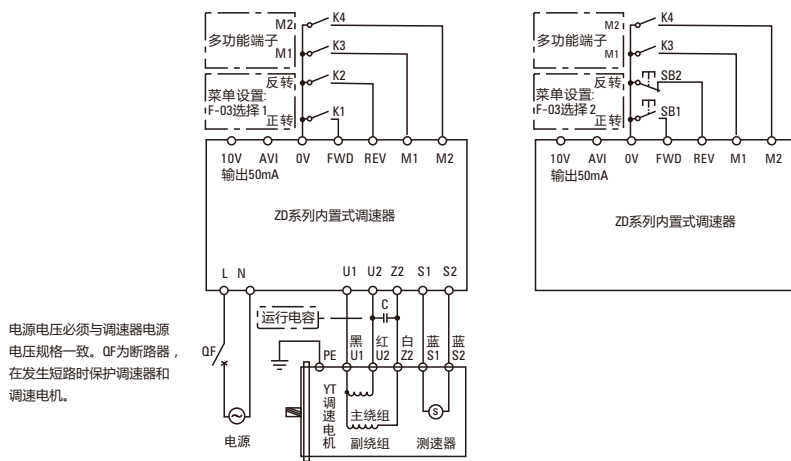

● QF断路器规格表 QF circuit breaker specification sheet

电源电压 Supply Voltage	电机功率 Motor Power	Qf电流规格 QF current specification
220V	6~90W	1A
220V	120~200W	2A
110V	6~90W	2A
110V	120~200W	4A

■ 内置式调速器安装规格图 Built-in Governor Installation Specifications

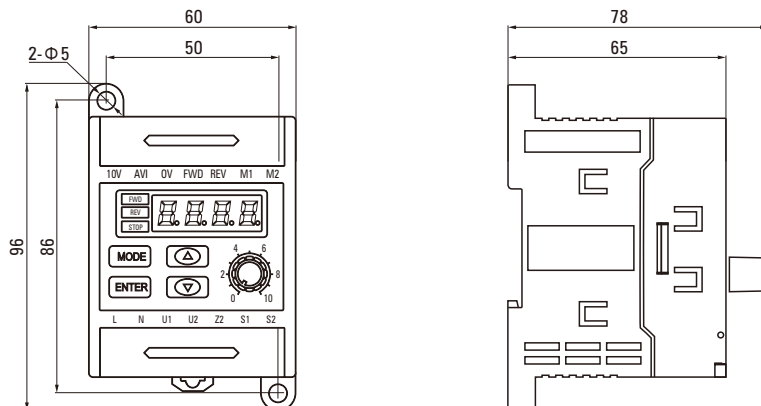

内置式调速器菜单 Built-in Governor Menu

● 菜单修改: Menu modification:

注意: 为保证安全, F-03、F-05、F-29参数修改必须在电机停止状态下进行, 否则无法, 屏幕显示“Err”。

Note: in order to ensure safety, F-03, F-05, F-29 parameters must be modified in the motor to stop the state, otherwise unable to, the screen display “Err”.

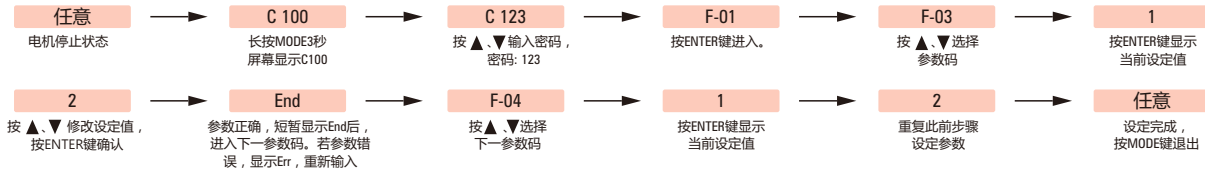

内置式调速菜单清单: Built-in Speed Control Menu List:

参数码	参数功能	设定范围	功能说明	出厂设定
F-01	显示内容	1. 电机转速设定值 2. 倍率转速设定值	倍率转速设定值=电机转速设定值÷倍率	1
F-02	倍率设定	1.0-999.9	根据显示直观性需要设定, 显示目标值。	1.0
F-03	运转控制方式	1. 正转/反转 2. 正转/停止	选择正转/反转, 电机由K1、K2开关控制。 选择正转/停止, 电机由SB1、SB2按钮控制。	1
F-04	旋转方式	1. 允许正反转 2. 允许正转, 禁止反转 3. 允许反转, 禁止正转	限制电机旋转方向, 防止设备故障或事故。 当F-03选择2时, F-04自动选择2且无法修改, 若需改变旋转方向可由F-05设定。	1
F-05	旋转方向	1. 不取反 2. 取反	无需改变电机接线, 轻而易举改变电机转向, 使之与习惯或要求一致。	1
F-06	主速调整方式	1. 面板按钮 2. 面板旋钮 3. 外部0~10V模拟量	1. 当任意闭合多功能端子M1、M2时, 电机运行方式为段速, 主速调整无效。 2. 面板旋钮、外部0-10V模拟量自动匹配0~最高转速。 3. 由于外接调速电位器连接于0-10V模拟量AVI输入端, 故采用外接调速电位器调速时, 主速调整方式F-06应选择3。	1
F-07	最高转速	500-3000	限制电机最高转速, 可防止超速, 发生损坏或事故。	1400
F-08	最低转速	90-1000	限制电机最低转速, 可防止电机由于运行低速导致不稳定, 过热, 过载。	1.0
F-09	正转起 加速时间	0-10秒 (自动匹配) 0.1-10秒 (手动匹配)	设置时间长, 电机起停平缓, 起停时间长。 设置时间短, 电机起停快, 起停时间短。	1.0
F-10	正转停止方式	1. 自由减速停止 2. 快速停止 3. 缓慢减速停止	1. 若选择自由减速停止, 电机停止较慢, 可选择快速停止, 改变F-11设定值, 改变快速停止快慢。 2. 若选择自由减速停止, 电机停止较快, 可选择缓慢减速停止, 改变F-12设定值, 改变缓慢减速停止的快慢。	1
F-11	正转停止时 缓慢减速时间	1~10	F-10选择2时, 菜单有效, 数值越大, 停止越快。	5
F-12	正转停止时 缓慢减速时间	0.1~10.0秒	F-10选择3时, 菜单有效, 数值越大, 停止越慢。	1.0
F-13	反转起 加速时间	0.1~10.0秒	时间长, 电机起停平缓, 起停时间长。 时间短, 电机起停快, 起停时间短。	1.0
F-14	反转停止方式	1. 自由减速停止 2. 快速停止 3. 缓慢减速停止	1. 若选择自由减速停止, 电机停止较慢, 可选择快速停止, 改变F-15设定值, 改变快速停止快慢。 2. 若选择自由减速停止, 电机停止较快, 可选择缓慢减速停止, 改变F-16设定值, 改变缓慢减速停止的快慢。	1
F-15	反转停止时 快速停止强度	1~10	F-14选择2时, 菜单有效, 数值越大, 停止越快。	5
F-16	反转停止时 缓慢减速时间	0.1~10.0秒	F-14选择3时, 菜单有效, 数值越大, 停止越慢。	1.0
F-17	第一段速	最低转速~最高转速	闭合多功能端子M1, 电机以第一段速运转。	500
F-18	第二段速	最低转速~最高转速	闭合多功能端子M2, 电机以第二段速运转。	700
F-19	第三段速	最低转速~最高转速	同时闭合多功能端子M1、M2, 电机以第三段速运转。	900
F-29	恢复出厂设定	1. 不恢复 2. 恢复出厂设定		1
F-30	程序版本	代码+版本		02.**
故障报警Er-1:		故障处理:		
1. 过载堵转		1. 检查、排除故障		
2. 调速器与电机的连接异常		2. 重新上电解除故障		